

5

Matter Waves

Chapter Outline

- | | |
|--|--|
| 5.1 The Pilot Waves of de Broglie <i>De Broglie's Explanation of Quantization in the Bohr Model</i> | 5.7 The Wave–Particle Duality <i>The Description of Electron Diffraction in Terms of Ψ A Thought Experiment: Measuring Through Which Slit the Electron Passes</i> |
| 5.2 The Davisson–Germer Experiment <i>The Electron Microscope</i> | 5.8 A Final Note Summary |
| 5.3 Wave Groups and Dispersion <i>Matter Wave Packets</i> | |
| 5.4 Fourier Integrals (Optional) <i>Constructing Moving Wave Packets</i> | |
| 5.5 The Heisenberg Uncertainty Principle <i>A Different View of the Uncertainty Principle</i> | |
| 5.6 If Electrons Are Waves, What's Waving? | |

In the previous chapter we discussed some important discoveries and theoretical concepts concerning the *particle nature of matter*. We now point out some of the shortcomings of these theories and introduce the fascinating and bizarre *wave properties of particles*. Especially notable are Count Louis de Broglie's remarkable ideas about how to represent electrons (and other particles) as waves and the experimental confirmation of de Broglie's hypothesis by the electron diffraction experiments of Davisson and Germer. We shall also see how the notion of representing a particle as a localized wave or wave group leads naturally to limitations on simultaneously measuring position and momentum of the particle. Finally, we discuss the passage of electrons through a double slit as a way of “understanding” the wave–particle duality of matter.



Figure 5.1 Louis de Broglie was a member of an aristocratic French family that produced marshals, ambassadors, foreign ministers, and at least one duke, his older brother Maurice de Broglie. Louis de Broglie came rather late to theoretical physics, as he first studied history. Only after serving as a radio operator in World War I did he follow the lead of his older brother and begin his studies of physics. Maurice de Broglie was an outstanding experimental physicist in his own right and conducted experiments in the palatial family mansion in Paris. (*AIP Meggers Gallery of Nobel Laureates*)

5.1 THE PILOT WAVES OF DE BROGLIE

By the early 1920s scientists recognized that the Bohr theory contained many inadequacies:

- It failed to predict the observed intensities of spectral lines.
- It had only limited success in predicting emission and absorption wavelengths for multielectron atoms.
- It failed to provide an equation of motion governing the time development of atomic systems starting from some initial state.
- It overemphasized the particle nature of matter and could not explain the newly discovered wave–particle duality of light.
- It did not supply a general scheme for “quantizing” other systems, especially those without periodic motion.

The first bold step toward a new mechanics of atomic systems was taken by Louis Victor de Broglie in 1923 (Fig. 5.1). In his doctoral dissertation he postulated that *because photons have wave and particle characteristics, perhaps all forms of matter have wave as well as particle properties*. This was a radical idea with no experimental confirmation at that time. According to de Broglie, electrons had a dual particle–wave nature. Accompanying every electron was a wave (not an electromagnetic wave!), which guided, or “piloted,” the electron through space. He explained the source of this assertion in his 1929 Nobel prize acceptance speech:

On the one hand the quantum theory of light cannot be considered satisfactory since it defines the energy of a light corpuscle by the equation $E = hf$ containing the frequency f . Now a purely corpuscular theory contains nothing that enables us to define a frequency; for this reason alone, therefore, we are compelled, in the case of light, to introduce the idea of a corpuscle and that of periodicity simultaneously. On the other hand, determination of the stable motion of electrons in the atom introduces integers, and up to this point the only phenomena involving integers in physics were those of interference and of normal modes of vibration. This fact suggested to me the idea that electrons too could not be considered simply as corpuscles, but that periodicity must be assigned to them also.

Let us look at de Broglie’s ideas in more detail. He concluded that the wavelength and frequency of a *matter wave* associated with any moving object were given by

$$\lambda = \frac{h}{p} \quad (5.1)$$

and

$$f = \frac{E}{h} \quad (5.2)$$

where h is Planck’s constant, p is the relativistic momentum, and E is the total relativistic energy of the object. Recall from Chapter 2 that p and E can be written as

$$p = \gamma mv \quad (5.3)$$

and

$$E^2 = p^2 c^2 + m^2 c^4 = \gamma^2 m^2 c^4 \quad (5.4)$$

where $\gamma = (1 - v^2/c^2)^{-1/2}$ and v is the object's speed. Equations 5.1 and 5.2 immediately suggest that it should be easy to calculate the speed of a de Broglie wave from the product λf . However, as we will show later, this is not the speed of the particle. Since the correct calculation is a bit complicated, we postpone it to Section 5.3. Before taking up the question of the speed of matter waves, we prefer first to give some introductory examples of the use of $\lambda = h/p$ and a brief description of how de Broglie waves provide a physical picture of the Bohr theory of atoms.

De Broglie's Explanation of Quantization in the Bohr Model

Bohr's model of the atom had many shortcomings and problems. For example, as the electrons revolve around the nucleus, how can one understand the fact that only certain electronic energies are allowed? Why do all atoms of a given element have precisely the same physical properties regardless of the infinite variety of starting velocities and positions of the electrons in each atom?

De Broglie's great insight was to recognize that although these are deep problems for particle theories, wave theories of matter handle these problems neatly by means of interference. For example, a plucked guitar string, although initially subjected to a wide range of wavelengths, supports only standing wave patterns that have nodes at each end. Thus only a discrete set of wavelengths is allowed for standing waves, while other wavelengths not included in this discrete set rapidly vanish by destructive interference. This same reasoning can be applied to electron matter waves bent into a circle around the nucleus. Although initially a continuous distribution of wavelengths may be present, corresponding to a distribution of initial electron velocities, most wavelengths and velocities rapidly die off. The residual standing wave patterns thus account for the identical nature of all atoms of a given element and show that atoms are more like vibrating drum heads with discrete modes of vibration than like miniature solar systems. This point of view is emphasized in Figure 5.2, which shows the standing wave pattern of the electron in the hydrogen atom corresponding to the $n = 3$ state of the Bohr theory.

Another aspect of the Bohr theory that is also easier to visualize physically by using de Broglie's hypothesis is the quantization of angular momentum. One simply assumes that **the allowed Bohr orbits arise because the electron matter waves interfere constructively when an integral number of wavelengths exactly fits into the circumference of a circular orbit.** Thus

$$n\lambda = 2\pi r \quad (5.5)$$

where r is the radius of the orbit. From Equation 5.1, we see that $\lambda = h/m_e v$. Substituting this into Equation 5.5, and solving for $m_e v r$, the angular momentum of the electron, gives

$$m_e v r = n\hbar \quad (5.6)$$

Note that this is precisely the Bohr condition for the quantization of angular momentum.

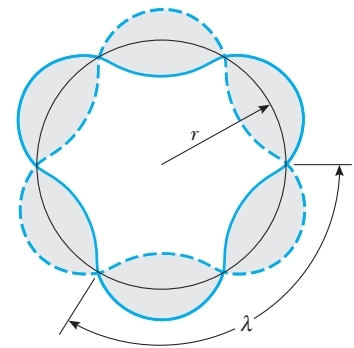

Figure 5.2 Standing waves fit to a circular Bohr orbit. In this particular diagram, three wavelengths are fit to the orbit, corresponding to the $n = 3$ energy state of the Bohr theory.

EXAMPLE 5.1 Why Don't We See the Wave Properties of a Baseball?

An object will appear “wavelike” if it exhibits interference or diffraction, both of which require scattering objects or apertures of about the same size as the wavelength. A baseball of mass 140 g traveling at a speed of 60 mi/h (27 m/s) has a de Broglie wavelength given by

$$\lambda = \frac{h}{p} = \frac{6.63 \times 10^{-34} \text{ J}\cdot\text{s}}{(0.14 \text{ kg})(27 \text{ m/s})} = 1.7 \times 10^{-34} \text{ m}$$

Even a nucleus (whose size is $\approx 10^{-15}$ m) is much too large to diffract this incredibly small wavelength! This explains why all macroscopic objects appear particle-like.

EXAMPLE 5.2 What Size “Particles” Do Exhibit Diffraction?

A particle of charge q and mass m is accelerated from rest through a small potential difference V . (a) Find its de Broglie wavelength, assuming that the particle is non-relativistic.

Solution When a charge is accelerated from rest through a potential difference V , its gain in kinetic energy, $\frac{1}{2}mv^2$, must equal the loss in potential energy qV . That is,

$$\frac{1}{2}mv^2 = qV$$

Because $p = mv$, we can express this in the form

$$\frac{p^2}{2m} = qV \quad \text{or} \quad p = \sqrt{2mqV}$$

Substituting this expression for p into the de Broglie relation $\lambda = h/p$ gives

$$\lambda = \frac{h}{p} = \frac{h}{\sqrt{2mqV}}$$

(b) Calculate λ if the particle is an electron and $V = 50$ V.

Solution The de Broglie wavelength of an electron accelerated through 50 V is

$$\begin{aligned} \lambda &= \frac{h}{\sqrt{2m_e q V}} \\ &= \frac{6.63 \times 10^{-34} \text{ J}\cdot\text{s}}{\sqrt{2(9.11 \times 10^{-31} \text{ kg})(1.6 \times 10^{-19} \text{ C})(50 \text{ V})}} \\ &= 1.7 \times 10^{-10} \text{ m} = 1.7 \text{ \AA} \end{aligned}$$

This wavelength is of the order of atomic dimensions and the spacing between atoms in a solid. Such low-energy electrons are routinely used in electron diffraction experiments to determine atomic positions on a surface.

Exercise 1 (a) Show that the de Broglie wavelength for an electron accelerated from rest through a *large* potential difference, V , is

$$\lambda = \frac{12.27}{V^{1/2}} \left(\frac{V_e}{2m_e c^2} + 1 \right)^{-1/2} \quad (5.7)$$

where λ is in angstroms (\AA) and V is in volts. (b) Calculate the percent error introduced when $\lambda = 12.27/V^{1/2}$ is used instead of the correct relativistic expression for 10 MeV electrons.

Answer (b) 230%.

5.2 THE DAVISSON–GERMER EXPERIMENT

Direct experimental proof that electrons possess a wavelength $\lambda = h/p$ was furnished by the diffraction experiments of American physicists Clinton J. Davisson (1881–1958) and Lester H. Germer (1896–1971) at the Bell Laboratories in New York City in 1927 (Fig. 5.3).¹ In fact, de Broglie had already suggested in 1924 that a stream of electrons traversing a small aperture should exhibit diffraction phenomena. In 1925, Einstein was led to the necessity of postulating matter waves from an analysis of fluctuations of a molecular gas. In addition, he noted that a molecular beam should show small but measurable diffraction effects. In the same year, Walter Elsasser pointed out that the slow

¹C. J. Davisson and L. H. Germer, *Phys. Rev.* 30:705, 1927.



Figure 5.3 Clinton J. Davisson (left) and Lester H. Germer (center) at Bell Laboratories in New York City. (*Bell Laboratories, courtesy AIP Emilio Segrè Visual Archives*)

electron scattering experiments of C. J. Davisson and C. H. Kunsman at the Bell Labs could be explained by electron diffraction.

Clear-cut proof of the wave nature of electrons was obtained in 1927 by the work of Davisson and Germer in the United States and George P. Thomson (British physicist, 1892–1975, the son of J. J. Thomson) in England. Both cases are intriguing not only for their physics but also for their human interest. The first case was an accidental discovery, and the second involved the discovery of the particle properties of the electron by the father and the wave properties by the son.

The crucial experiment of Davisson and Germer was an offshoot of an attempt to understand the arrangement of atoms on the surface of a nickel sample by elastically scattering a beam of low-speed electrons from a polycrystalline nickel target. A schematic drawing of their apparatus is shown in Figure 5.4. Their device allowed for the variation of three experimental parameters—electron energy; nickel target orientation, α ; and scattering angle, ϕ . Before a fortunate accident occurred, the results seemed quite pedestrian. For constant electron energies of about 100 eV, the scattered intensity rapidly decreased as ϕ increased. But then someone dropped a flask of liquid air on the glass vacuum system, rupturing the vacuum and oxidizing the nickel target, which had been at high temperature. To remove the oxide, the sample was reduced by heating it cautiously² in a flowing stream of hydrogen. When the apparatus was reassembled, quite different results were found: Strong variations in the intensity of scattered electrons with angle were observed, as shown in Figure 5.5. The prolonged heating had evidently annealed the nickel target, causing large single-crystal regions to develop in the polycrystalline sample. These crystalline regions furnished the extended regular lattice needed to observe electron diffraction. Once Davisson and Germer realized that it was the elastic scattering from *single crystals* that produced such unusual results (1925), they initiated a thorough investigation of elastic scattering from large single crystals

²At present this can be done without the slightest fear of “stinks or bangs,” because 5% hydrogen–95% argon safety mixtures are commercially available.

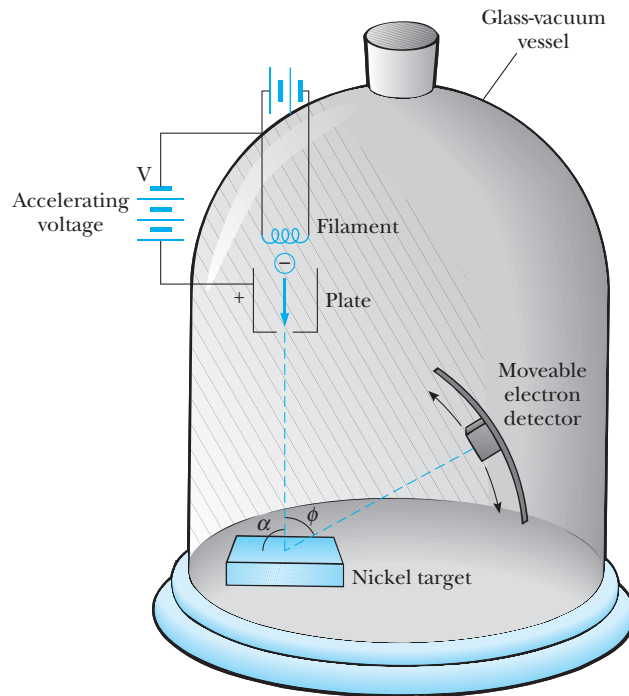

Figure 5.4 A schematic diagram of the Davisson–Germer apparatus.

with predetermined crystallographic orientation. Even these experiments were not conducted at first as a test of de Broglie’s wave theory, however. Following discussions with Richardson, Born, and Franck, the experiments and their analysis finally culminated in 1927 in the proof that electrons experience diffraction with an electron wavelength that is given by $\lambda = h/p$.

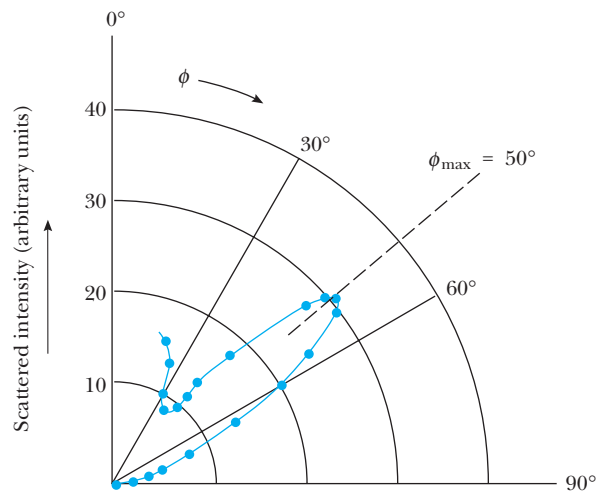

Figure 5.5 A polar plot of scattered intensity versus scattering angle for 54-eV electrons, based on the original work of Davisson and Germer. The scattered intensity is proportional to the distance of the point from the origin in this plot.

The idea that electrons behave like waves when interacting with the atoms of a crystal is so striking that Davisson and Germer's proof deserves closer scrutiny. In effect, they calculated the wavelength of electrons from a simple diffraction formula and compared this result with de Broglie's formula $\lambda = h/p$. Although they tested this result over a wide range of target orientations and electron energies, we consider in detail only the simple case shown in Figures 5.4 and 5.5 with $\alpha = 90.0^\circ$, $V = 54.0$ V, and $\phi = 50.0^\circ$, corresponding to the $n = 1$ diffraction maximum. In order to calculate the de Broglie wavelength for this case, we first obtain the velocity of a nonrelativistic electron accelerated through a potential difference V from the energy relation

$$\frac{1}{2} m_e v^2 = eV$$

Substituting $v = \sqrt{2Ve/m_e}$ into the de Broglie relation gives

$$\lambda = \frac{h}{m_e v} = \frac{h}{\sqrt{2Vem_e}} \quad (5.8)$$

Thus the wavelength of 54.0-V electrons is

$$\begin{aligned} \lambda &= \frac{6.63 \times 10^{-34} \text{ J}\cdot\text{s}}{\sqrt{2(54.0 \text{ V})(1.60 \times 10^{-19} \text{ C})(9.11 \times 10^{-31} \text{ kg})}} \\ &= 1.67 \times 10^{-10} \text{ m} = 1.67 \text{ \AA} \end{aligned}$$

The experimental wavelength may be obtained by considering the nickel atoms to be a reflection diffraction grating, as shown in Figure 5.6. Only the surface layer of atoms is considered because low-energy electrons, unlike x-rays, do not penetrate deeply into the crystal. Constructive interference occurs when the path length difference between two adjacent rays is an integral number of wavelengths or

$$d \sin \phi = n\lambda \quad (5.9)$$

As d was known to be 2.15 \AA from x-ray diffraction measurements, Davisson and Germer calculated λ to be

$$\lambda = (2.15 \text{ \AA})(\sin 50.0^\circ) = 1.65 \text{ \AA}$$

in excellent agreement with the de Broglie formula.

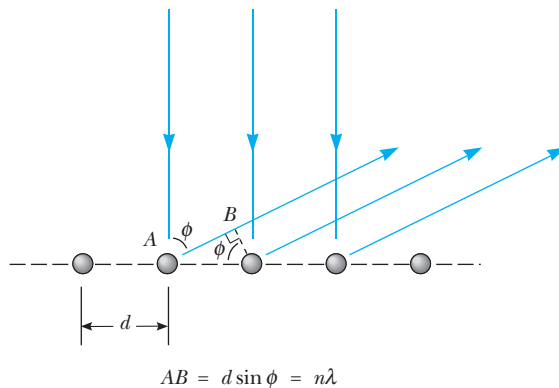

Figure 5.6 Constructive interference of electron matter waves scattered from a single layer of atoms at an angle ϕ .



Figure 5.7 Diffraction of 50-kV electrons from a film of Cu_3Au . The alloy film was 400 \AA thick. (Courtesy of the late Dr. L. H. Germer)

It is interesting to note that while the diffraction lines from low-energy reflected electrons are quite broad (see Fig. 5.5), the lines from high-energy electrons transmitted through metal foils are quite sharp (see Fig. 5.7). This effect occurs because hundreds of atomic planes are penetrated by high-energy electrons, and consequently Equation 5.9, which treats diffraction from a surface layer, no longer holds. Instead, the Bragg law, $2d \sin \theta = n\lambda$, applies to high-energy electron diffraction. The maxima are extremely sharp in this case because if $2d \sin \theta$ is not exactly equal to $n\lambda$, there will be no diffracted wave. This occurs because there are scattering contributions from so many atomic planes that eventually the path length difference between the wave from the first plane and some deeply buried plane will be *an odd multiple of $\lambda/2$* , resulting in complete cancellation of these waves (see Problem 13).

If de Broglie's postulate is true for all matter, then any object of mass m has wavelike properties and a wavelength $\lambda = h/p$. In the years following Davisson and Germer's discovery, experimentalists tested the universal character of de Broglie's postulate by searching for diffraction of other "particle" beams. In subsequent experiments, diffraction was observed for helium atoms (Estermann and Stern in Germany) and hydrogen atoms (Johnson in the United States). Following the discovery of the neutron in 1932, it was shown that neutron beams of the appropriate energy also exhibit diffraction when incident on a crystalline target (Fig. 5.8).

Image not available due to copyright restrictions

EXAMPLE 5.3 Thermal Neutrons

What kinetic energy (in electron volts) should neutrons have if they are to be diffracted from crystals?

Solution Appreciable diffraction will occur if the de Broglie wavelength of the neutron is of the same order of magnitude as the interatomic distance. Taking $\lambda = 1.00 \text{ \AA}$, we find

$$p = \frac{h}{\lambda} = \frac{6.63 \times 10^{-34} \text{ J}\cdot\text{s}}{1.00 \times 10^{-10} \text{ m}} = 6.63 \times 10^{-24} \text{ kg}\cdot\text{m/s}$$

The kinetic energy is given by

$$\begin{aligned} K &= \frac{p^2}{2m_n} = \frac{(6.63 \times 10^{-24} \text{ J}\cdot\text{s})^2}{2(1.66 \times 10^{-27} \text{ kg})} \\ &= 1.32 \times 10^{-20} \text{ J} = 0.0825 \text{ eV} \end{aligned}$$

Note that these neutrons are nonrelativistic because K is much less than the neutron rest energy of 940 MeV, and so our use of the classical expression $K = p^2/2m_n$ is justified. Because the average thermal energy of a par-

ticle in thermal equilibrium is $\frac{1}{2}k_B T$ for each independent direction of motion, neutrons at room temperature (300 K) possess a kinetic energy of

$$\begin{aligned} K &= \frac{3}{2}k_B T = (1.50)(8.62 \times 10^{-5} \text{ eV/K})(300 \text{ K}) \\ &= 0.0388 \text{ eV} \end{aligned}$$

Thus "thermal neutrons," or neutrons in thermal equilibrium with matter at room temperature, possess energies of the right order of magnitude to diffract appreciably from single crystals. Neutrons produced in a nuclear reactor are far too energetic to produce diffraction from crystals and must be slowed down in a graphite column as they leave the reactor. In the graphite moderator, repeated collisions with carbon atoms ultimately reduce the average neutron energies to the average thermal energy of the carbon atoms. When this occurs, these so-called thermalized neutrons possess a distribution of velocities and a corresponding distribution of de Broglie wavelengths with average wavelengths comparable to crystal spacings.

Exercise 2 *Monochromatic Neutrons.* A beam of neutrons with a single wavelength may be produced by means of a mechanical velocity selector of the type shown in Figure 5.9. (a) Calculate the speed of neutrons with a wavelength of 1.00 \AA . (b) What rotational speed (in rpm) should the shaft have in order to pass neutrons with wavelength of 1.00 \AA ?

Answers (a) $3.99 \times 10^3 \text{ m/s}$. (b) 13,300 rev/min.

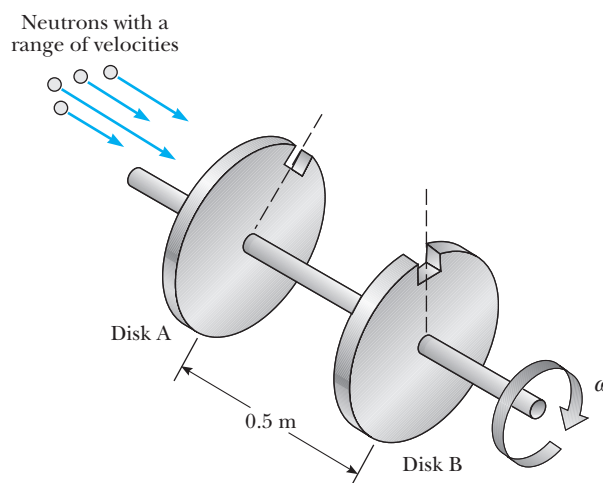

Figure 5.9 A neutron velocity selector. The slot in disk B lags the slot in disk A by 10° .

The Electron Microscope

The idea that electrons have a controllable wavelength that can be made much shorter than visible light wavelengths and, accordingly, possess a much better ability to resolve fine details was only one of the factors that led to the development of the electron microscope. In fact, ideas of such a device were tossed about in the cafés and bars of Paris and Berlin as early as 1928. What really made the difference was the coming together of several lines of development—electron tubes and circuits, vacuum technology, and electron beam control—all pioneered in the development of the cathode ray tube (CRT). These factors led to the construction of the first transmission electron microscope (TEM) with magnetic lenses by electrical engineers Max Knoll and Ernst Ruska in Berlin in 1931. The testament to the fortitude and brilliance of Knoll and Ruska in overcoming the “cussedness of objects” and building and getting such a complicated experimental device to work for the first time is shown in Figure 5.10. It is remarkable that although the overall performance of the TEM has been improved thousands of times since its invention, it is basically the same in principle as that first designed by Knoll and Ruska: a device that focuses electron beams with magnetic lenses and creates a flat-looking two-dimensional shadow pattern on its screen, the result of varying degrees of electron transmission through the object. Figure 5.11a is a diagram showing this basic design and Figure 5.11b shows, for comparison, an optical projection microscope. The best optical microscopes using ultraviolet light have a magnification of about 2000 and can resolve two objects separated by 100 nm, but a TEM using electrons accelerated through 100 kV has a magnification of as much as 1,000,000 and a maximum resolution of 0.2 nm. In practice, magnifications of 10,000 to 100,000 are easier to use. Figure 5.12 shows typical TEM micrographs of microbes, Figure 5.12b showing a microbe and its DNA strands magnified 40,000 times. Although it would seem that increasing electron energy should lead to shorter electron wavelength and increased resolution, imperfections or aberrations in the magnetic lenses actually set the limit of resolution at about 0.2 nm. Increasing electron energy above 100 keV does not



Ernst Ruska played a major role in the invention of the TEM. He was awarded the Nobel prize in physics for this work in 1986. (AIP Emilio Segre Visual Archives, W. F. Meggers Gallery of Nobel Laureates)

Image not available due to copyright restrictions

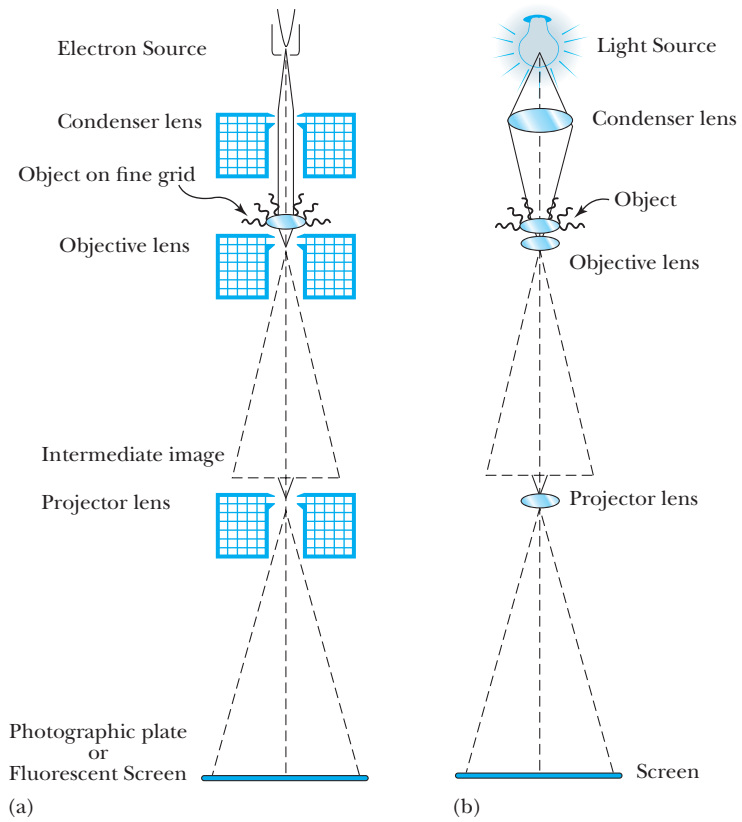

Figure 5.11 (a) Schematic drawing of a transmission electron microscope with magnetic lenses. (b) Schematic of a light-projection microscope.

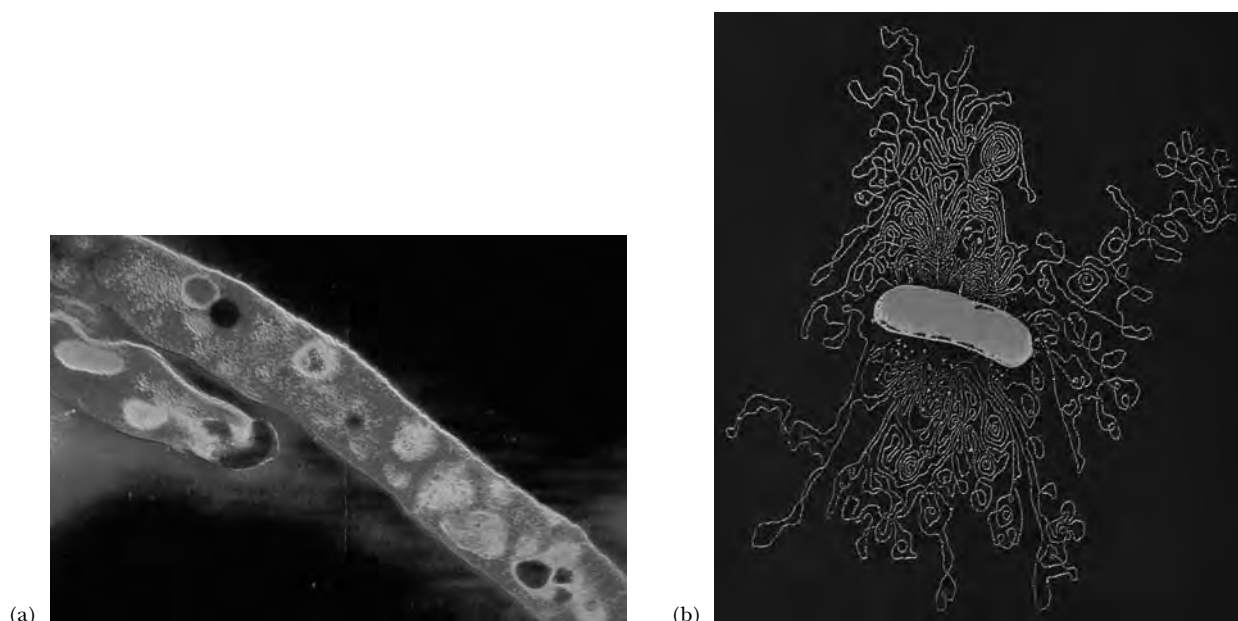

Figure 5.12 (a) A false-color TEM micrograph of tuberculosis bacteria. (b) A TEM micrograph of a microbe leaking DNA ($\times 40,000$). (CNRI/Photo Researchers, Inc., Dr. Gopal Murti/Photo Researchers, Inc.)

improve resolution—it only permits electrons to sample regions deeper inside an object. Figures 5.13a and 5.13b show, respectively, a diagram of a modern TEM and a photo of the same instrument.

A second type of electron microscope with less resolution and magnification than the TEM, but capable of producing striking three-dimensional images, is the scanning electron microscope (SEM). Figure 5.14 shows dramatic three-dimensional SEM micrographs made possible by the large range of focus (depth of field) of the SEM, which is several hundred times better than that of a light microscope. The SEM was the brainchild of the same Max Knoll who helped invent the TEM. Knoll had recently moved to the television department at Telefunken when he conceived of the idea in 1935. The SEM produces a sort of giant television image by collecting electrons scattered from an object, rather than light. The first operating scanning microscope was built by M. von Ardenne in 1937, and it was extensively developed and perfected by Vladimir Zworykin and collaborators at RCA Camden in the early 1940s.

Figure 5.15 shows how a typical SEM works. Such a device might be operated with 20-keV electrons and have a resolution of about 10 nm and a magnification ranging from 10 to 100,000. As shown in Figure 5.15, an electron beam is sharply focused on a specimen by magnetic lenses and then scanned (rastered) across a tiny region on the surface of the specimen. The high-energy primary beam scatters lower-energy secondary electrons out of the object depending on specimen composition and surface topography. These secondary electrons are detected by a plastic scintillator coupled to a photomultiplier, amplified, and used to modulate the brightness of a simultaneously

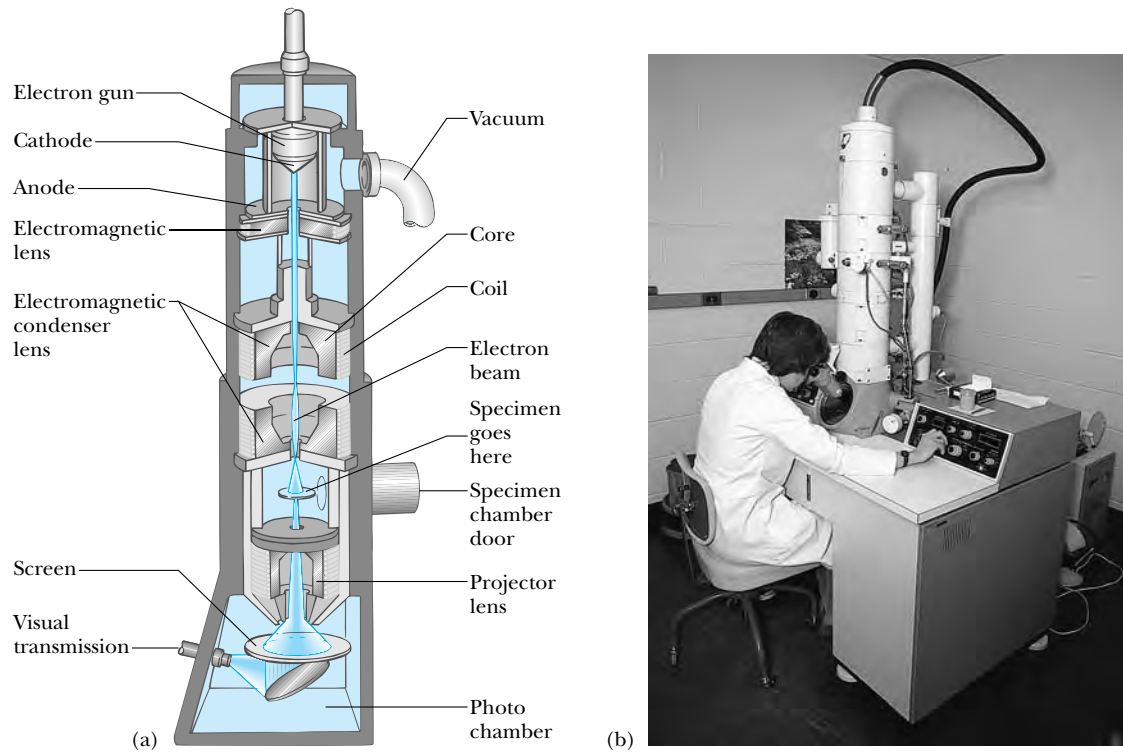

Figure 5.13 (a) Diagram of a transmission electron microscope. (b) A photo of the same TEM. (*W. Ormerod/Visuals Unlimited*)

rastered display CRT. The ratio of the display raster size to the microscope electron beam raster size determines the magnification. Modern SEM's can also collect x-rays and high-energy electrons from the specimen to detect chemical elements at certain locations on the specimen's surface, thus answering the bonus question, "Is the bitty bump on the bilayer boron or bismuth?"

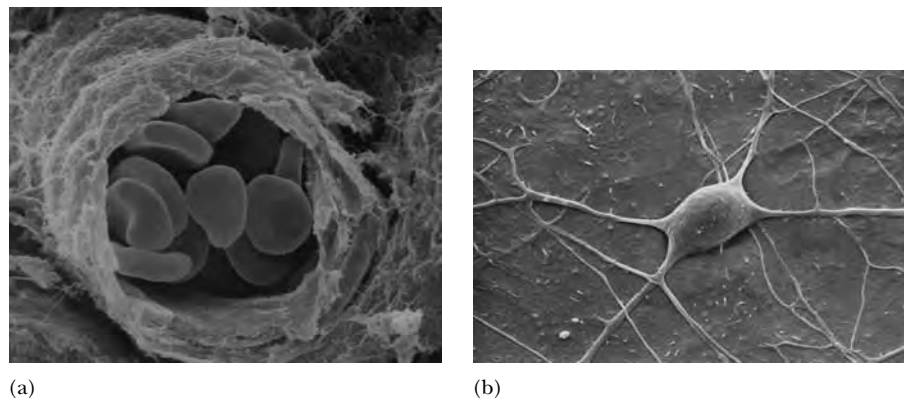

Figure 5.14 (a) A SEM micrograph showing blood cells in a tiny artery. (b) A SEM micrograph of a single neuron ($\times 4000$). (*P. Motta & S. Correr/Photo Researchers, Inc., David McCarthy/Photo Researchers, Inc.*)

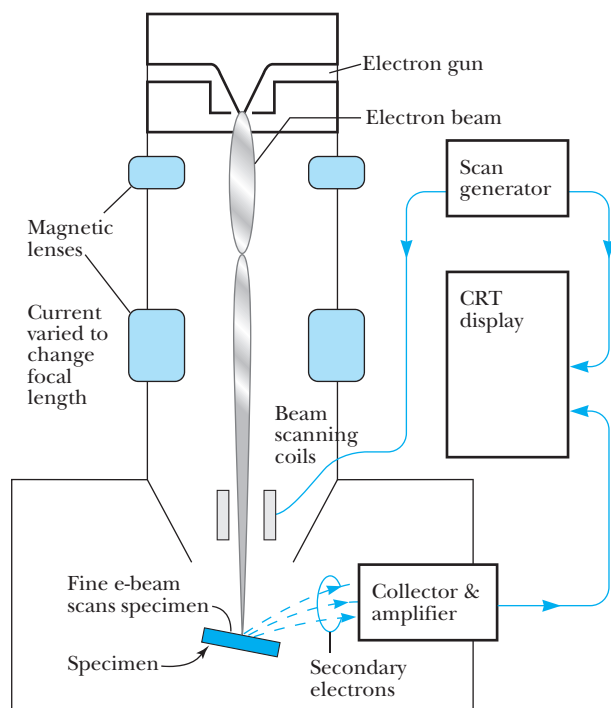

Figure 5.15 The working parts of a scanning electron microscope.

The newer, higher-resolution scanning tunneling microscope (STM) and atomic force microscope (AFM), which can image individual atoms and molecules, are discussed in Chapter 7. These instruments are exciting not only for their superb pictures of surface topography and individual atoms (see Figure 5.16 for an AFM picture) but also for their potential as microscopic machines capable of detecting and moving a few atoms at a time in proposed microchip terabit memories and mass spectrometers.

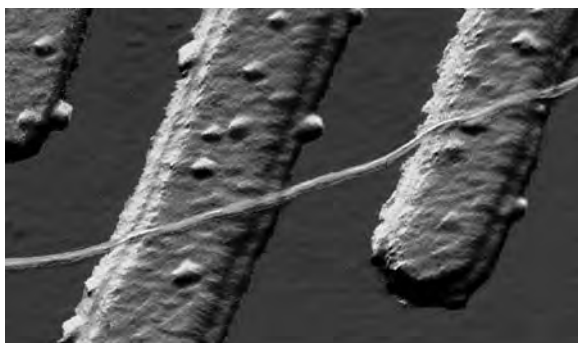

Figure 5.16 World's smallest electrical wire. An AFM image of a carbon nanotube wire on platinum electrodes. The wire is 1.5 nm wide, a mere 10 atoms. The magnification is 120,000. (*Delft University of Technology/Photo Researchers, Inc.*)

5.3 WAVE GROUPS AND DISPERSION

The matter wave representing a moving particle must reflect the fact that the particle has a large probability of being found in a small region of space only at a specific time. This means that a traveling sinusoidal matter wave of infinite extent and constant amplitude cannot properly represent a localized moving particle. What is needed is a pulse, or “wave group,” of limited spatial extent. Such a pulse can be formed by adding sinusoidal waves with different wavelengths. The resulting wave group can then be shown to move with a speed v_g (the group speed) identical to the classical particle speed. This argument is shown schematically in Figure 5.17 and will be treated in detail after the introduction of some general ideas about wave groups.

Actually, all observed waves are limited to definite regions of space and are called *pulses*, *wave groups*, or *wave packets* in the case of matter waves. The plane wave with an exact wavelength and infinite extension is an abstraction. Water waves from a stone dropped into a pond, light waves emerging from a briefly opened shutter, a wave generated on a taut rope by a single flip of one end, and a sound wave emitted by a discharging capacitor must all be modeled by wave groups. A wave group consists of a superposition of waves with *different wavelengths*, with the amplitude and phase of each component wave adjusted so that the waves interfere constructively over a small region of space. Outside of this region the combination of waves produces a net amplitude that approaches zero rapidly as a result of destructive interference. Perhaps the most familiar physical example in which wave groups arise is the phenomenon of beats. Beats occur when two sound waves of slightly different wavelength (and hence different frequency) are combined. The resultant sound wave has a frequency equal to the average of the two combining waves and an amplitude that fluctuates, or “beats,” at a rate

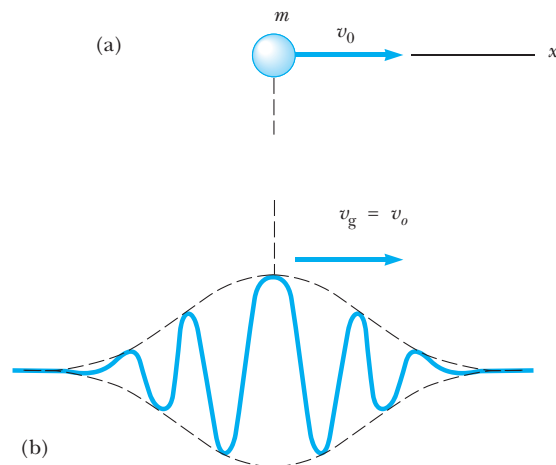

Figure 5.17 Representing a particle with matter waves: (a) particle of mass m and speed v_0 ; (b) superposition of many matter waves with a spread of wavelengths centered on $\lambda_0 = h/mv_0$ correctly represents a particle.

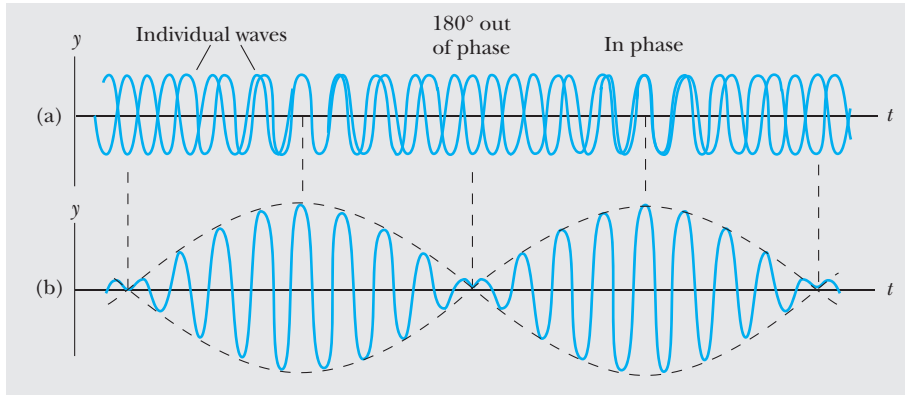

Figure 5.18 Beats are formed by the combination of two waves of slightly different frequency traveling in the same direction. (a) The individual waves. (b) The combined wave has an amplitude (broken line) that oscillates in time.

given by the difference of the two original frequencies. This case is illustrated in Figure 5.18.

Let us examine this situation mathematically. Consider a one-dimensional wave propagating in the positive x direction with a *phase speed* v_p . Note that v_p is the speed of a point of constant phase on the wave, such as a wave crest or trough. This traveling wave with wavelength λ , frequency f , and amplitude A may be described by

$$y = A \cos\left(\frac{2\pi x}{\lambda} - 2\pi f t\right) \quad (5.10)$$

where λ and f are related by

$$v_p = \lambda f \quad (5.11)$$

A more compact form for Equation 5.10 results if we take $\omega = 2\pi f$ (where ω is the *angular frequency*) and $k = 2\pi/\lambda$ (where k is the *wavenumber*). With these substitutions the infinite wave becomes

$$y = A \cos(kx - \omega t) \quad (5.12)$$

with

$$v_p = \frac{\omega}{k} \quad (5.13)$$

Phase velocity

Let us now form the superposition of two waves of equal amplitude both traveling in the positive x direction but with slightly different wavelengths, frequencies, and phase velocities. The resultant amplitude y is given by

$$y = y_1 + y_2 = A \cos(k_1 x - \omega_1 t) + A \cos(k_2 x - \omega_2 t)$$

Using the trigonometric identity

$$\cos a + \cos b = 2 \cos \frac{1}{2}(a - b) \cdot \cos \frac{1}{2}(a + b)$$

we find

$$y = 2A \cos \frac{1}{2} \{ (k_2 - k_1)x - (\omega_2 - \omega_1)t \} \cdot \cos \frac{1}{2} \{ (k_1 + k_2)x - (\omega_1 + \omega_2)t \} \tag{5.14}$$

For the case of two waves with slightly different values of k and ω , we see that $\Delta k = k_2 - k_1$ and $\Delta \omega = \omega_2 - \omega_1$ are small, but $(k_1 + k_2)$ and $(\omega_1 + \omega_2)$ are large. Thus, Equation 5.14 may be interpreted as a broad sinusoidal envelope

$$2A \cos \left(\frac{\Delta k}{2} x - \frac{\Delta \omega}{2} t \right)$$

limiting or modulating a high-frequency wave within the envelope

$$\cos \left[\frac{1}{2} (k_1 + k_2)x - \frac{1}{2} (\omega_1 + \omega_2)t \right]$$

This superposition of two waves is shown in Figure 5.19.

Although our model is primitive and does not represent a pulse limited to a small region of space, it shows several interesting features common to more complicated models. For example, the envelope and the wave within the envelope move at different speeds. The speed of either the high-frequency wave or the envelope is given by dividing the coefficient of the t term by the coefficient of the x term as was done in Equations 5.12 and 5.13. For the wave *within the envelope*,

$$v_p = \frac{(\omega_1 + \omega_2)/2}{(k_1 + k_2)/2} \approx \frac{\omega_1}{k_1} = v_1$$

Thus, the high-frequency wave moves at the phase velocity v_1 of one of the waves or at v_2 because $v_1 \approx v_2$. The envelope or group described by $2A \cos[(\Delta k/2)x - (\Delta \omega/2)t]$ moves with a different velocity however, the group velocity given by

$$v_g = \frac{(\omega_2 - \omega_1)/2}{(k_2 - k_1)/2} = \frac{\Delta \omega}{\Delta k} \tag{5.15}$$

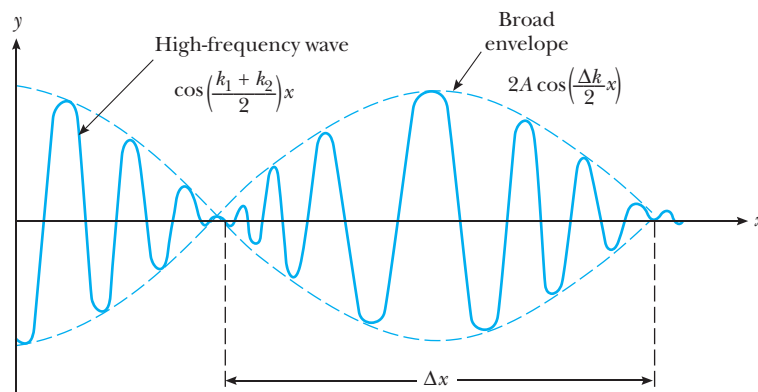

Figure 5.19 Superposition of two waves of slightly different wavelengths resulting in primitive wave groups; t has been set equal to zero in Equation 5.14.

Another general characteristic of wave groups for waves of any type is both a limited duration in time, Δt , and a limited extent in space, Δx . It is found that the smaller the spatial width of the pulse, Δx , the larger the range of wavelengths or wavenumbers, Δk , needed to form the pulse. This may be stated mathematically as

$$\Delta x \Delta k \approx 1 \quad (5.16)$$

Likewise, if the time duration, Δt , of the pulse is small, we require a wide spread of frequencies, $\Delta \omega$, to form the group. That is,

$$\Delta t \Delta \omega \approx 1 \quad (5.17)$$

In pulse electronics, this condition is known as the “response time–bandwidth formula.”³ In this situation Equation 5.17 shows that in order to amplify a voltage pulse of time width Δt without distortion, a pulse amplifier must equally amplify all frequencies in a frequency band of width $\Delta \omega$.

Equations 5.16 and 5.17 are important because they constitute “uncertainty relations,” or “reciprocity relations,” for pulses of any kind—electromagnetic, sound, or even matter waves. In particular, Equation 5.16 shows that Δx , the uncertainty in spatial extent of a pulse, is inversely proportional to Δk , the range of wavenumbers making up the pulse: **both Δx and Δk cannot become arbitrarily small, but as one decreases the other must increase.**

It is interesting that our simple two-wave model also shows the general principles given by Equations 5.16 and 5.17. If we call (rather artificially) the spatial extent of our group the distance between adjacent minima (labeled Δx in Figure 5.12), we find from the envelope term $2A \cos(\frac{1}{2}\Delta kx)$ the condition $\frac{1}{2}\Delta k \Delta x = \pi$ or

$$\Delta k \Delta x = 2\pi \quad (5.18)$$

Here, $\Delta k = k_2 - k_1$ is the range of wavenumbers present. Likewise, if x is held constant and t is allowed to vary in the envelope portion of Equation 5.14, the result is $\frac{1}{2}(\omega_2 - \omega_1) \Delta t = \pi$, or

$$\Delta \omega \Delta t = 2\pi \quad (5.19)$$

Therefore, Equations 5.18 and 5.19 agree with the general principles, respectively, of $\Delta k \Delta x \approx 1$ and $\Delta \omega \Delta t \approx 1$.

The addition of only two waves with discrete frequencies is instructive but produces an infinite wave instead of a true pulse. In the general case, many waves having a continuous distribution of wavelengths must be added to form a packet that is finite over a limited range and really zero everywhere else. In this case Equation 5.15 for the **group velocity**, v_g becomes

$$v_g = \left. \frac{d\omega}{dk} \right|_{k_0} \quad (5.20)$$

Group velocity

³It should be emphasized that Equations 5.16 and 5.17 are true in general and that the quantities Δx , Δk , Δt , and $\Delta \omega$ represent the spread in values present in an *arbitrary* pulse formed from the superposition of two or *more* waves.

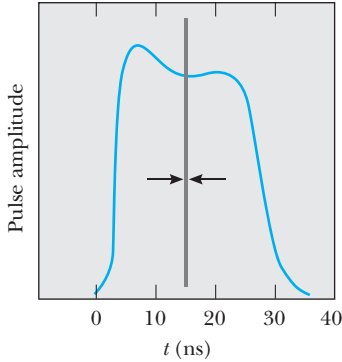

Figure 5.20 Dispersion in a 1-ns laser pulse. A pulse that starts with the width shown by the vertical lines has a time width of approximately 30 ns after traveling 1 km along an optical fiber.

where the derivative is to be evaluated at k_0 , the central wavenumber of the many waves present. The connection between the group velocity and the phase velocity of the composite waves is easily obtained. Because $\omega = kv_p$, we find

$$v_g = \left. \frac{d\omega}{dk} \right|_{k_0} = v_p \Big|_{k_0} + k \left. \frac{dv_p}{dk} \right|_{k_0} \tag{5.21}$$

where v_p is the phase velocity and is, in general, a function of k or λ . Materials in which the phase velocity varies with wavelength are said to exhibit **dispersion**. An example of a dispersive medium is glass, in which the index of refraction varies with wavelength and different colors of light travel at different speeds. Media in which the phase velocity does not vary with wavelength (such as vacuum for electromagnetic waves) are termed *nondispersive*. The term *dispersion* arises from the fact that the individual harmonic waves that form a pulse travel at different phase velocities and cause an originally sharp pulse to change shape and become spread out, or dispersed. As an example, dispersion of a laser pulse after traveling 1 km along an optical fiber is shown in Figure 5.20. In a nondispersive medium where all waves have the same velocity, the group velocity is equal to the phase velocity. In a dispersive medium the group velocity can be less than or greater than the phase velocity, depending on the sign of dv_p/dk , as shown by Equation 5.21.

EXAMPLE 5.4 Group Velocity in a Dispersive Medium

In a particular substance the phase velocity of waves doubles when the wavelength is halved. Show that wave groups in this system move at twice the *central* phase velocity.

Solution From the given information, the dependence of phase velocity on wavelength must be

$$v_p = \frac{A'}{\lambda} = Ak$$

for some constants A' and A . From Equation 5.21 we obtain

$$v_g = v_p \Big|_{k_0} + k \left. \frac{dv_p}{dk} \right|_{k_0} = Ak_0 + Ak_0 = 2Ak_0$$

Thus,

$$v_g = 2v_p \Big|_{k_0}$$

EXAMPLE 5.5 Group Velocity in Deep Water Waves

Newton showed that the phase velocity of deep water waves having wavelength λ is given by

$$v_p = \sqrt{\frac{g\lambda}{2\pi}}$$

where g is the acceleration of gravity and where the minor contribution of surface tension has been ignored. Show that in this case the velocity of a group of these waves is one-half of the phase velocity of the central wavelength.

Solution Because $k = 2\pi/\lambda$, we can write v_p as

$$v_p = \left(\frac{g}{k}\right)^{1/2}$$

Therefore, we find

$$\begin{aligned} v_g &= v_p \Big|_{k_0} + k \left. \frac{dv_p}{dk} \right|_{k_0} = \left(\frac{g}{k_0}\right)^{1/2} - \frac{1}{2} \left(\frac{g}{k_0}\right)^{1/2} \\ &= \frac{1}{2} \left(\frac{g}{k_0}\right)^{1/2} \equiv \frac{1}{2} v_p \Big|_{k_0} \end{aligned}$$

Matter Wave Packets

We are now in a position to apply our general theory of wave groups to electrons. We shall show both the dispersion of de Broglie waves and the satisfying result that the wave packet and the particle move at the same velocity. According to de Broglie, *individual* matter waves have a frequency f and a wavelength λ given by

$$f = \frac{E}{h} \quad \text{and} \quad \lambda = \frac{h}{p}$$

where E and p are the relativistic energy and momentum of the particle, respectively. The phase speed of these matter waves is given by

$$v_p = f\lambda = \frac{E}{p} \quad (5.22)$$

The phase speed can be expressed as a function of p or k alone by substituting $E = (p^2c^2 + m^2c^4)^{1/2}$ into Equation 5.22:

$$v_p = c \sqrt{1 + \left(\frac{mc}{p}\right)^2} \quad (5.23)$$

The dispersion relation for de Broglie waves can be obtained as a function of k by substituting $p = h/\lambda = \hbar k$ into Equation 5.23. This gives

$$v_p = c \sqrt{1 + \left(\frac{mc}{\hbar k}\right)^2} \quad (5.24)$$

Phase velocity of matter waves

Equation 5.24 shows that individual de Broglie waves representing a particle of mass m show dispersion even in *empty space* and always travel at a speed that is *greater than* or at least equal to c . Because these component waves travel at different speeds, the width of the wave packet, Δx , spreads or disperses as time progresses, as will be seen in detail in Chapter 6. To obtain the group speed, we use

$$v_g = \left[v_p + k \frac{dv_p}{dk} \right]_{k_0}$$

and Equation 5.24. After some algebra, we find

$$v_g = \frac{c}{\left[1 + \left(\frac{mc}{\hbar k_0}\right)^2 \right]^{1/2}} = \frac{c^2}{v_p} \Big|_{k_0} \quad (5.25)$$

Solving for the phase speed from Equation 5.22, we find

$$v_p = \frac{E}{p} = \frac{\gamma mc^2}{\gamma mv} = \frac{c^2}{v}$$

where v is the particle's speed. Finally, substituting $v_p = c^2/v$ into Equation 5.25 for v_g shows that the group velocity of the matter wave packet is the same as the particle speed. This agrees with our intuition that the matter wave envelope should move at the same speed as the particle.

O P T I O N A L

5.4 FOURIER INTEGRALS

In this section we show in detail how to construct wave groups, or pulses, that are truly localized in space or time and also show that very general reciprocity relations of the type $\Delta k \Delta x \approx 1$ and $\Delta \omega \Delta t \approx 1$ hold for these pulses.

To form a true pulse that is zero everywhere outside of a finite spatial range Δx requires adding together an infinite number of harmonic waves with continuously varying wavelengths and amplitudes. This addition can be done with a Fourier integral, which is defined as follows:

$$f(x) = \frac{1}{\sqrt{2\pi}} \int_{-\infty}^{+\infty} a(k) e^{ikx} dk \tag{5.26}$$

Here $f(x)$ is a spatially localized wave group, $a(k)$ gives the amount or amplitude of the wave with wavenumber $k = (2\pi/\lambda)$ to be added, and $e^{ikx} = \cos kx + i \sin kx$ is Euler's compact expression for a harmonic wave. The amplitude distribution function $a(k)$ can be obtained if $f(x)$ is known by using the symmetric formula

$$a(k) = \frac{1}{\sqrt{2\pi}} \int_{-\infty}^{+\infty} f(x) e^{-ikx} dx \tag{5.27}$$

Equations 5.26 and 5.27 apply to the case of a spatial pulse at fixed time, but it is important to note that they are mathematically identical to the case of a time pulse passing a fixed position. This case is common in electrical engineering and involves adding together a continuously varying set of frequencies:

$$V(t) = \frac{1}{\sqrt{2\pi}} \int_{-\infty}^{+\infty} g(\omega) e^{i\omega t} d\omega \tag{5.28}$$

$$g(\omega) = \frac{1}{\sqrt{2\pi}} \int_{-\infty}^{+\infty} V(t) e^{-i\omega t} dt \tag{5.29}$$

where $V(t)$ is the strength of a signal as a function of time, and $g(\omega)$ is the *spectral content* of the signal and gives the amount of the harmonic wave with frequency ω that is present.

Let us now consider several examples of how to use Equations 5.26 through 5.29 and how they lead to uncertainty relationships of the type $\Delta \omega \Delta t \approx 1$ and $\Delta k \Delta x \approx 1$.

EXAMPLE 5.6

This example compares the spectral contents of infinite and truncated sinusoidal waves. A truncated sinusoidal wave is a wave cut off or truncated by a shutter, as shown in Figure 5.21. (a) What is the spectral content of an infinite sinusoidal wave $e^{i\omega_0 t}$? (b) Find and sketch the spectral content of a truncated sinusoidal wave given by

$$V(t) = e^{i\omega_0 t} \quad -T < t < +T$$

$$V(t) = 0 \quad \text{otherwise}$$

(c) Show that for this truncated sinusoid $\Delta t \Delta \omega = \pi$, where Δt and $\Delta \omega$ are the half-widths of $v(t)$ and $g(\omega)$, respectively.

Solution (a) The spectral content consists of a single strong contribution at the frequency ω_0 .

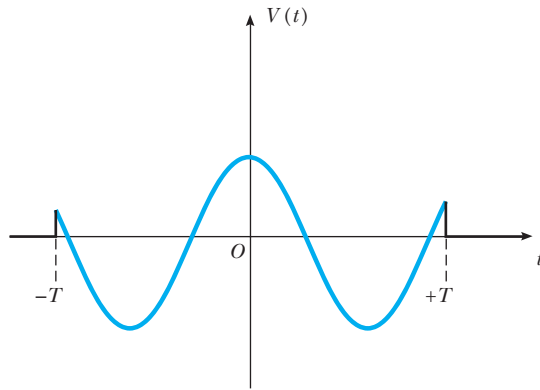

Figure 5.21 (Example 5.6) The real part of a truncated sinusoidal wave.

$$\begin{aligned}
 \text{(b)} \quad g(\omega) &= \frac{1}{\sqrt{2\pi}} \int_{-\infty}^{+\infty} V(t) e^{-i\omega t} dt = \frac{1}{\sqrt{2\pi}} \int_{-T}^{+T} e^{i(\omega_0 - \omega)t} dt \\
 &= \frac{1}{\sqrt{2\pi}} \int_{-T}^{+T} [\cos(\omega_0 - \omega)t + i \sin(\omega_0 - \omega)t] dt
 \end{aligned}$$

Because the sine term is an odd function and the cosine is even, the integral reduces to

$$g(\omega) = \frac{2}{\sqrt{2\pi}} \int_0^T \cos(\omega_0 - \omega)t dt = \sqrt{\frac{2}{\pi}} \frac{\sin(\omega_0 - \omega)T}{(\omega_0 - \omega)} = \sqrt{\frac{2}{\pi}} (T) \frac{\sin(\omega_0 - \omega)T}{(\omega_0 - \omega)T}$$

A sketch of $g(\omega)$ (Figure 5.22) shows a typical $\text{sin } Z/Z$ profile centered on ω_0 . Note that both positive and negative amounts of different frequencies must be added to produce the truncated sinusoid. Furthermore, the strongest frequency contribution comes from the frequency region near $\omega = \omega_0$, as expected.

(c) Δt clearly equals T and $\Delta\omega$ may be taken to be half the width of the main lobe of $g(\omega)$, $\Delta\omega = \pi/T$. Thus, we get

$$\Delta\omega \Delta t = \frac{\pi}{T} \times T = \pi$$

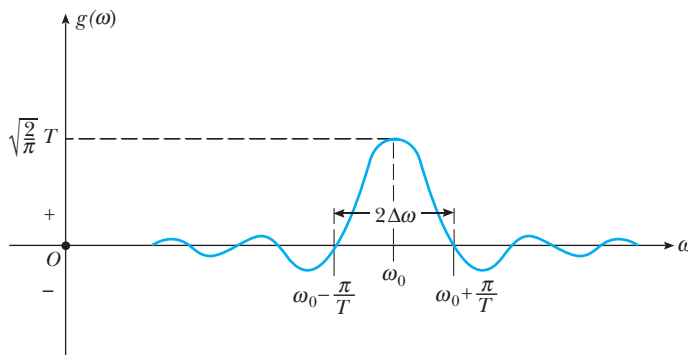

Figure 5.22 (Example 5.6) The Fourier transform of a truncated sinusoidal wave. The curve shows the amount of a given frequency that must be added to produce the truncated wave.

We see that the product of the spread in frequency, $\Delta\omega$, and the spread in time, Δt , is a constant independent of T .

EXAMPLE 5.7 A Matter Wave Packet

(a) Show that the matter wave packet whose amplitude distribution $a(k)$ is a rectangular pulse of height unity, width Δk , and centered at k_0 (Fig. 5.23) has the form

$$f(x) = \frac{\Delta k}{\sqrt{2\pi}} \frac{\sin(\Delta k \cdot x/2)}{(\Delta k \cdot x/2)} e^{ik_0x}$$

Solution

$$\begin{aligned} f(x) &= \frac{1}{\sqrt{2\pi}} \int_{-\infty}^{+\infty} a(k) e^{ikx} dk = \frac{1}{\sqrt{2\pi}} \int_{k_0 - (\Delta k/2)}^{k_0 + (\Delta k/2)} e^{ikx} dk = \frac{1}{\sqrt{2\pi}} \frac{e^{ik_0x}}{x} 2 \sin(\Delta k \cdot x/2) \\ &= \frac{\Delta k}{\sqrt{2\pi}} \frac{\sin(\Delta k \cdot x/2)}{(\Delta k \cdot x/2)} e^{ik_0x} \end{aligned}$$

(b) Observe that this wave packet is a complex function. Later in this chapter we shall see how the definition of probability density results in a real function, but for the time being consider only the real part of $f(x)$ and make a sketch of its behavior, showing its envelope and the cosine function within. Determine Δx , and show that an uncertainty relation of the form $\Delta x \Delta k \approx 1$ holds.

Solution The real part of the wave packet is shown in Figure 5.24 where the full width of the main lobe is $\Delta x = 4\pi/\Delta k$. This immediately gives the uncertainty relation $\Delta x \Delta k = 4\pi$. Note that the constant on the right-hand side of the uncertainty relation depends on the shape chosen for $a(k)$ and the precise definition of Δx and Δk .

Exercise 3 Assume that a narrow triangular voltage pulse $V(t)$ arises in some type of radar system (see Fig. 5.25). (a) Find and sketch the spectral content $g(\omega)$. (b) Show that a relation of the type $\Delta\omega \Delta t \approx 1$ holds. (c) If the width of the pulse is

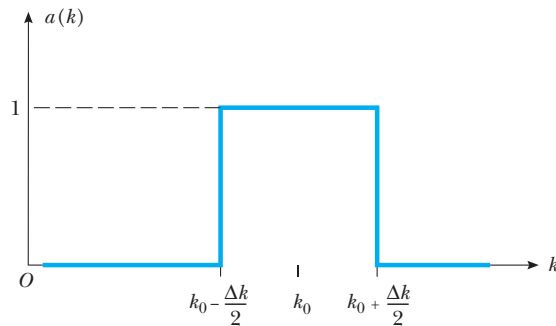

Figure 5.23 (Example 5.7) A simple amplitude distribution specifying a uniform contribution of all wavenumbers from $k_0 - \Delta k/2$ to $k_0 + \Delta k/2$. Although we have used only positive k 's here, both positive and negative k values are allowed, in general corresponding to waves traveling to the right ($k > 0$) or left ($k < 0$).

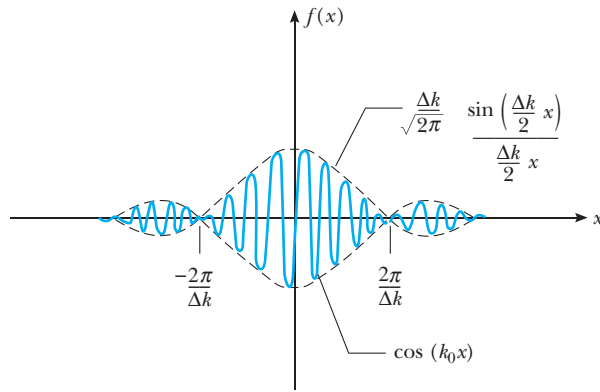

Figure 5.24 (Example 5.7) The real part of the wave packet formed by the uniform amplitude distribution shown in Figure 5.23.

$2\tau = 10^{-9}$ s, what range of frequencies must this system pass if the pulse is to be undistorted? Take $\Delta t = \tau$ and define $\Delta\omega$ similarly.

Answer (a) $g(\omega) = (\sqrt{2/\pi})(1/\omega^2\tau)(1 - \cos \omega\tau)$. (b) $\Delta\omega \Delta t = 2\pi$. (c) $2\Delta f = 4.00 \times 10^9$ Hz.

Constructing Moving Wave Packets

Figure 5.24 represents a snapshot of the wave packet at $t = 0$. To construct a moving wave packet representing a moving particle, we replace kx in Equation 5.26 with $(kx - \omega t)$. Thus, the representation of the moving wave packet becomes

$$f(x, t) = \frac{1}{\sqrt{2\pi}} \int_{-\infty}^{+\infty} a(k) e^{i(kx - \omega t)} dk \tag{5.30}$$

It is important to realize that here $\omega = \omega(k)$, that is, ω is a function of k and therefore depends on the type of wave and the medium traversed. In general, it is difficult to solve this integral analytically. For matter waves, the QMTools software available from our companion Web site (<http://info.brookscole.com/mp3e>) produces the same result by solving numerically a certain differential equation that governs the behavior of such waves. This approach will be explored further in the next chapter.

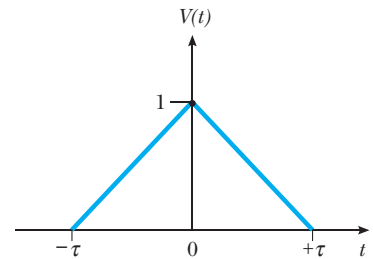

Figure 5.25 (Exercise 3).

5.5 THE HEISENBERG UNCERTAINTY PRINCIPLE

In the period 1924–25, Werner Heisenberg, the son of a professor of Greek and Latin at the University of Munich, invented a complete theory of quantum mechanics called matrix mechanics. This theory overcame some of the problems with the Bohr theory of the atom, such as the postulate of “unobservable” electron orbits. Heisenberg’s formulation was based primarily on measurable quantities such as the transition probabilities for electronic jumps between quantum states. Because transition probabilities depend on the initial and final states, Heisenberg’s mechanics used variables labeled by two subscripts. Although at first Heisenberg presented his theory in the form of non-commuting algebra, Max Born quickly realized that this theory could be more

elegantly described by matrices. Consequently, Born, Heisenberg, and Pascual Jordan soon worked out a comprehensive theory of matrix mechanics. Although the matrix formulation was quite elegant, it attracted little attention outside of a small group of gifted physicists because it was difficult to apply in specific cases, involved mathematics unfamiliar to most physicists, and was based on rather vague physical concepts.

Although we will investigate this remarkable form of quantum mechanics no further, we shall discuss another of Heisenberg's discoveries, the **uncertainty principle**, elucidated in a famous paper in 1927. In this paper Heisenberg introduced the notion that **it is impossible to determine simultaneously with unlimited precision the position and momentum of a particle**. In words we may state the uncertainty principle as follows:

**Momentum–position
uncertainty principle**

If a measurement of position is made with precision Δx and a simultaneous measurement of momentum in the x direction is made with precision Δp_x , then the product of the two uncertainties can never be smaller than $\hbar/2$. That is,

$$\Delta p_x \Delta x \geq \frac{\hbar}{2} \quad (5.31)$$

In his paper of 1927, Heisenberg was careful to point out that the inescapable uncertainties Δp_x and Δx do not arise from imperfections in practical measuring instruments. Rather, they arise from the need to use a large range of wavenumbers, Δk , to represent a matter wave packet localized in a small region, Δx . The uncertainty principle represents a sharp break with the ideas of classical physics, in which it is assumed that, with enough skill and ingenuity, it is possible to simultaneously measure a particle's position and momentum to any desired degree of precision. As shown in Example 5.8, however, there is no contradiction between the uncertainty principle and classical laws for macroscopic systems because of the small value of \hbar .

One can show that $\Delta p_x \Delta x \geq \hbar/2$ comes from the uncertainty relation governing any type of wave pulse formed by the superposition of waves with different wavelengths. In Section 5.3 we found that to construct a wave group localized in a small region Δx , we had to add up a large range of wavenumbers Δk , where $\Delta k \Delta x \approx 1$ (Eq. 5.16). The precise value of the number on the right-hand side of Equation 5.16 depends on the functional form $f(x)$ of the wave group as well as on the specific definition of Δx and Δk . A different choice of $f(x)$ or a different rule for defining Δx and Δk (or both) will give a slightly different number. With Δx and Δk defined as standard deviations, it can be shown that the smallest number, $\frac{1}{2}$, is obtained for a Gaussian wavefunction.⁴ In this minimum uncertainty case we have

$$\Delta x \Delta k = \frac{1}{2}$$

⁴See Section 6.7 for a definition of the standard deviation and Problem 6.34 for a complete mathematical proof of this statement.

This photograph of Werner Heisenberg was taken around 1924. Heisenberg obtained his Ph.D. in 1923 at the University of Munich where he studied under Arnold Sommerfeld and became an enthusiastic mountain climber and skier. Later, he worked as an assistant to Max Born at Göttingen and Niels Bohr in Copenhagen. While physicists such as de Broglie and Schrödinger tried to develop visualizable models of the atom, Heisenberg, with the help of Born and Pascual Jordan, developed an abstract mathematical model called matrix mechanics to explain the wavelengths of spectral lines. The more successful wave mechanics of Schrödinger an-

Image not available due to copyright restrictions

WERNER HEISENBERG
(1901–1976)

nounced a few months later was shown to be equivalent to Heisenberg’s approach. Heisenberg made many other significant contributions to physics, including his famous uncertainty principle, for which he received the Nobel prize in 1932, the prediction of two forms of molecular hydrogen, and theoretical models of the nucleus. During World War II he was director of the Max Planck Institute at Berlin where he was in charge of German research on atomic weapons. Following the war, he moved to West Germany and became director of the Max Planck Institute for Physics at Göttingen.

For any other choice of $f(x)$,

$$\Delta x \Delta k \geq \frac{1}{2} \tag{5.32}$$

and using $\Delta p_x = \hbar \Delta k$, $\Delta x \Delta k \geq \frac{1}{2}$ immediately becomes

$$\Delta p_x \Delta x \geq \frac{\hbar}{2} \tag{5.33}$$

The basic meaning of $\Delta p \Delta x \geq \hbar/2$ is that as one uncertainty increases the other decreases. In the extreme case as one uncertainty approaches ∞ , the other must approach zero. This extreme case is illustrated by a plane wave e^{ik_0x} that has a precise momentum $\hbar k_0$ and an infinite extent—that is, the wavefunction is not concentrated in any segment of the x axis.

Another important uncertainty relation involves the uncertainty in energy of a wave packet, ΔE , and the time, Δt , taken to measure that energy. Starting with $\Delta \omega \Delta t \geq \frac{1}{2}$ as the minimum form of the time–frequency uncertainty principle, and using the de Broglie relation for the connection between the matter wave energy and frequency, $E = \hbar \omega$, we immediately find the **energy–time uncertainty principle**

$$\Delta E \Delta t \geq \frac{\hbar}{2} \tag{5.34}$$

Energy–time uncertainty principle

Equation 5.34 states that the precision with which we can know the energy of some system is limited by the time available for measuring the energy. A common application of the energy–time uncertainty is in calculating the lifetimes of very short-lived subatomic particles whose lifetimes cannot be measured directly, but whose uncertainty in energy or mass can be measured. (See Problem 26.)

A Different View of the Uncertainty Principle

Although we have indicated that $\Delta p_x \Delta x \geq \hbar/2$ arises from the theory of forming pulses or wave groups, there is a more physical way to view the origin of the un-

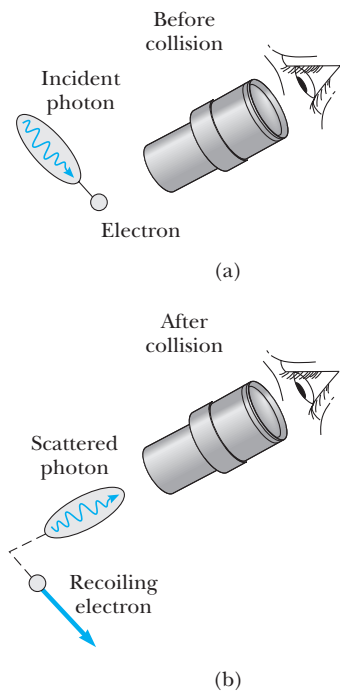

Figure 5.26 A thought experiment for viewing an electron with a powerful microscope. (a) The electron is shown before colliding with the photon. (b) The electron recoils (is disturbed) as a result of the collision with the photon.

certainty principle. We consider certain idealized experiments (called *thought experiments*) and show that it is impossible to carry out an experiment that allows the position and momentum of a particle to be simultaneously measured with an accuracy that violates the uncertainty principle. The most famous thought experiment along these lines was introduced by Heisenberg himself and involves the measurement of an electron’s position by means of a microscope (Fig. 5.26), which forms an image of the electron on a screen or the retina of the eye.

Because light can scatter from and perturb the electron, let us minimize this effect by considering the scattering of only a single light quantum from an electron initially at rest (Fig. 5.27). To be collected by the lens, the photon must be scattered through an angle ranging from $-\theta$ to $+\theta$, which consequently imparts to the electron an x momentum value ranging from $+(h \sin \theta)/\lambda$ to $-(h \sin \theta)/\lambda$. Thus the uncertainty in the electron’s momentum is $\Delta p_x = (2h \sin \theta)/\lambda$. After passing through the lens, the photon lands somewhere on the screen, but the image and consequently the position of the electron is “fuzzy” because the photon is diffracted on passing through the lens aperture. According to physical optics, the resolution of a microscope or the uncertainty in the image of the electron, Δx , is given by $\Delta x = \lambda/(2 \sin \theta)$. Here 2θ is the angle subtended by the objective lens, as shown in Figure 5.27.⁵ Multiplying the expressions for Δp_x and Δx , we find for the electron

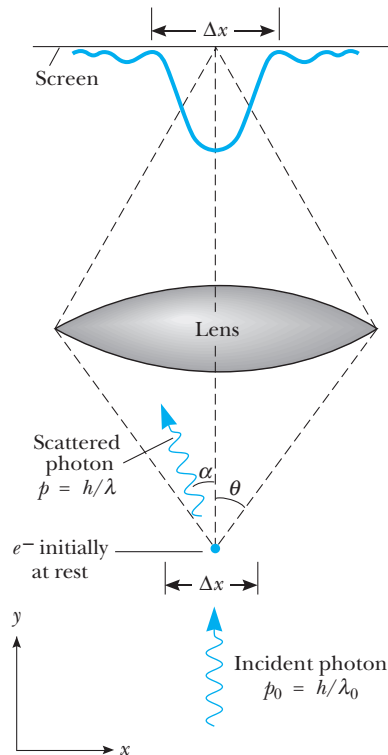

Figure 5.27 The Heisenberg microscope.

⁵The resolving power of the microscope is treated clearly in F. A. Jenkins and H. E. White, *Fundamentals of Optics*, 4th ed., New York, McGraw-Hill Book Co., 1976, pp. 332–334.

$$\Delta p_x \Delta x \approx \left(\frac{2h}{\lambda} \sin \theta \right) \left(\frac{\lambda}{2 \sin \theta} \right) = h$$

in agreement with the uncertainty relation. Note also that this principle is inescapable and relentless! If Δx is reduced by increasing θ or the lens size, there is an equivalent increase in the uncertainty of the electron's momentum.

Examination of this simple experiment shows several key physical properties that lead to the uncertainty principle:

- The indivisible nature of light particles or quanta (nothing less than a single photon can be used!).
- The wave property of light as shown in diffraction.
- The impossibility of predicting or measuring the precise classical path of a single scattered photon and hence of knowing the precise momentum transferred to the electron.⁶

We conclude this section with some examples of the types of calculations that can be done with the uncertainty principle. In the spirit of Fermi or Heisenberg, these “back-of-the-envelope calculations” are surprising for their simplicity and essential description of quantum systems of which the details are unknown.

EXAMPLE 5.8 The Uncertainty Principle Changes Nothing for Macroscopic Objects

(a) Show that the spread of velocities caused by the uncertainty principle does not have measurable consequences for macroscopic objects (objects that are large compared with atoms) by considering a 100-g racquetball confined to a room 15 m on a side. Assume the ball is moving at 2.0 m/s along the x axis.

Solution

$$\Delta p_x \geq \frac{\hbar}{2 \Delta x} = \frac{1.05 \times 10^{-34} \text{ J}\cdot\text{s}}{2 \times 15 \text{ m}} = 3.5 \times 10^{-36} \text{ kg}\cdot\text{m/s}$$

Thus the minimum spread in velocity is given by

$$\Delta v_x = \frac{\Delta p_x}{m} = \frac{3.05 \times 10^{-36} \text{ kg}\cdot\text{m/s}}{0.100 \text{ kg}} = 3.5 \times 10^{-35} \text{ m/s}$$

This gives a relative uncertainty of

$$\frac{\Delta v_x}{v_x} = \frac{3.5 \times 10^{-35}}{2.0} = 1.8 \times 10^{-35}$$

which is certainly not measurable.

(b) If the ball were to suddenly move along the y axis perpendicular to its well-defined classical trajectory along x , how far would it move in 1 s? Assume that the ball moves in the y direction with the top speed in the spread Δv_y produced by the uncertainty principle.

Solution It is important to realize that uncertainty relations hold in the y and z directions as well as in the x direction. This means that $\Delta p_x \Delta x \geq \hbar/2$, $\Delta p_y \Delta y \geq \hbar/2$, and $\Delta p_z \Delta z \geq \hbar/2$ and because all the position uncertainties are equal, all of the velocity spreads are equal. Consequently, we have $\Delta v_y = 3.5 \times 10^{-35} \text{ m/s}$ and the ball moves $3.5 \times 10^{-35} \text{ m}$ in the y direction in 1 s. This distance is again an immeasurably small quantity, being 10^{-20} times the size of a nucleus!

Exercise 4 How long would it take the ball to move 50 cm in the y direction? (The age of the universe is thought to be 15 billion years, give or take a few billion).

⁶Attempts to measure the photon's position by scattering electrons from it in a Compton process only serve to make its path to the lens more uncertain.

EXAMPLE 5.9 Do Electrons Exist Within the Nucleus?

Estimate the kinetic energy of an electron confined within a nucleus of size 1.0×10^{-14} m by using the uncertainty principle.

Solution Taking Δx to be the half-width of the confinement length in the equation $\Delta p_x \geq \frac{\hbar}{2 \Delta x}$, we have

$$\Delta p_x \geq \frac{6.58 \times 10^{-16} \text{ eV} \cdot \text{s}}{1.0 \times 10^{-14} \text{ m}} \times \frac{3.00 \times 10^8 \text{ m/s}}{c}$$

or

$$\Delta p_x \geq 2.0 \times 10^7 \frac{\text{eV}}{c}$$

This means that measurements of the component of momentum of electrons trapped inside a nucleus would range from less than $-20 \text{ MeV}/c$ to greater than $+20 \text{ MeV}/c$ and that some electrons would have momentum at least as large as $20 \text{ MeV}/c$. Because this appears to be a large momentum, to be safe we calculate the electron's energy relativistically.

$$\begin{aligned} E^2 &= p^2 c^2 + (m_e c^2)^2 \\ &= (20 \text{ MeV}/c)^2 c^2 + (0.511 \text{ MeV})^2 \\ &= 400(\text{MeV})^2 \end{aligned}$$

or

$$E \geq 20 \text{ MeV}$$

Finally, the kinetic energy of an intranuclear electron is

$$K = E - m_e c^2 \geq 19.5 \text{ MeV}$$

Since electrons emitted in radioactive decay of the nucleus (beta decay) have energies much less than 19.5 MeV (about 1 MeV or less) and it is known that no other mechanism could carry off an intranuclear electron's energy during the decay process, we conclude that electrons observed in beta decay do not come from within the nucleus but are actually created at the instant of decay.

EXAMPLE 5.10 The Width of Spectral Lines

Although an excited atom can radiate at any time from $t = 0$ to $t = \infty$, the average time after excitation at which a group of atoms radiates is called the **lifetime**, τ , of

a particular excited state. (a) If $\tau = 1.0 \times 10^{-8}$ s (a typical value), use the uncertainty principle to compute the line width Δf of light emitted by the decay of this excited state.

Solution We use $\Delta E \Delta t \approx \hbar/2$, where ΔE is the uncertainty in energy of the excited state, and $\Delta t = 1.0 \times 10^{-8}$ s is the average time available to measure the excited state. Thus,

$$\Delta E \approx \hbar/2 \Delta t = \hbar/(2.0 \times 10^{-8} \text{ s})$$

Since ΔE is also the uncertainty in energy of a photon emitted when the excited state decays, and $\Delta E = h\Delta f$ for a photon,

$$h \Delta f = \hbar/(2.0 \times 10^{-8} \text{ s})$$

or

$$\Delta f = \frac{1}{4\pi \times 10^{-8} \text{ s}} = 8.0 \times 10^6 \text{ Hz}$$

(b) If the wavelength of the spectral line involved in this process is 500 nm, find the fractional broadening $\Delta f/f$.

Solution First, we find the center frequency of this line as follows:

$$f_0 = \frac{c}{\lambda} = \frac{3.0 \times 10^8 \text{ m/s}}{500 \times 10^{-9} \text{ m}} = 6.0 \times 10^{14} \text{ Hz}$$

Hence,

$$\frac{\Delta f}{f_0} = \frac{8.0 \times 10^6 \text{ Hz}}{6.0 \times 10^{14} \text{ Hz}} = 1.3 \times 10^{-8}$$

This narrow natural line width can be seen with a sensitive interferometer. Usually, however, temperature and pressure effects overshadow the natural line width and broaden the line through mechanisms associated with the Doppler effect and atomic collisions.

Exercise 5 Using the nonrelativistic Doppler formula, calculate the Doppler broadening of a 500-nm line emitted by a hydrogen atom at 1000 K. Do this by considering the atom to be moving either directly toward or away from an observer with an energy of $\frac{3}{2}k_B T$.

Answer 0.0083 nm, or 0.083 Å.

5.6 IF ELECTRONS ARE WAVES, WHAT'S WAVING?

Although we have discussed in some detail the notion of de Broglie matter waves, we have not discussed the precise nature of the field $\Psi(x, y, z, t)$ or **wavefunction** that represents the matter waves. We have delayed this discussion because Ψ

(Greek letter psi) is rather abstract. Ψ is definitely *not* a measurable disturbance requiring a medium for propagation like a water wave or a sound wave. Instead, the stuff that is waving requires no medium. Furthermore, Ψ is in general represented by a complex number and is used to calculate the probability of finding the particle at a given time in a small volume of space. If any of this seems confusing, you should not lose heart, as the nature of the wavefunction has been confusing people since its invention. It even confused its inventor, Erwin Schrödinger, who incorrectly interpreted $\Psi^*\Psi$ as the electric charge density.⁷ The great philosopher of the quantum theory, Bohr, immediately objected to this interpretation. Subsequently, Max Born offered the currently accepted statistical view of $\Psi^*\Psi$ in late 1926. The confused state of affairs surrounding Ψ at that time was nicely described in a poem by Walter Huckel:

Erwin with his psi can do
Calculations quite a few.
But one thing has not been seen
Just what does psi really mean?
(English translation by Felix Bloch)

The currently held view is that a particle is described by a function $\Psi(x, y, z, t)$ called the **wavefunction**. The quantity $\Psi^*\Psi = |\Psi|^2$ represents the probability per unit volume of finding the particle at a time t in a small volume of space centered on (x, y, z) . We will treat methods of finding Ψ in much more detail in Chapter 6, but for now all we require is the idea that **the probability of finding a particle is directly proportional to $|\Psi|^2$** .

5.7 THE WAVE–PARTICLE DUALITY

The Description of Electron Diffraction in Terms of Ψ

In this chapter and previous chapters we have seen evidence for both the wave properties and the particle properties of electrons. Historically, the particle properties were first known and connected with a definite mass, a discrete charge, and detection or localization of the electron in a small region of space. Following these discoveries came the confirmation of the wave nature of electrons in scattering at low energy from metal crystals. In view of these results and because of the everyday experience of seeing the world in terms of *either* grains of sand *or* diffuse water waves, it is no wonder that we are tempted to simplify the issue and ask, “Well, is the electron a wave or a particle?” The answer is that **electrons are very delicate and rather plastic—they behave like either particles or waves, depending on the kind of experiment performed on them. In any case, it is impossible to measure both the wave and particle properties simultaneously.**⁸ The view of Bohr was expressed in an idea known as **complementarity**. As different as they are, both wave and particle views are needed and they complement each other to fully describe the electron. The view of

Complementarity

⁷ Ψ^* represents the complex conjugate of Ψ . Thus, if $\Psi = a + ib$, then $\Psi^* = a - ib$. In exponential form, if $\Psi = Ae^{i\theta}$, then $\Psi^* = Ae^{-i\theta}$. Note that $\Psi^*\Psi = |\Psi|^2$; a , b , A , and θ are all real quantities.

⁸Many feel that the elder Bragg’s remark, originally made about light, is a more satisfying answer: Electrons behave like waves on Mondays, Wednesdays, and Fridays, like particles on Tuesdays, Thursdays, and Saturdays, and like nothing at all on Sundays.

Feynman⁹ was that both electrons and photons behave in their own inimitable way. This is like nothing we have seen before, because we do not live at the very tiny scale of atoms, electrons, and photons.

Perhaps the best way to crystallize our ideas about the wave–particle duality is to consider a “simple” double-slit electron diffraction experiment. This experiment highlights much of the mystery of the wave–particle paradox, shows the impossibility of measuring *simultaneously* both wave and particle properties, and illustrates the use of the wavefunction, Ψ , in determining interference effects. A schematic of the experiment with monoenergetic (single-wavelength) electrons is shown in Figure 5.28. A parallel beam of electrons falls on a double slit, which has individual openings much smaller than D so that single-slit diffraction effects are negligible. At a distance from the slits much greater than D is an electron detector capable of detecting individual electrons. It is important to note that the detector always registers discrete particles localized in space and time. In a real experiment this can be achieved if the electron source is weak enough (see Fig. 5.29): **In all cases if the detector collects electrons at different positions for a long enough time, a typical wave interference pattern for the counts per minute or probability of arrival of electrons is found** (see Fig. 5.28). If one imagines a single electron to produce in-phase “wavelets” at the slits, standard wave theory can be used to find the angular separation, θ , of the

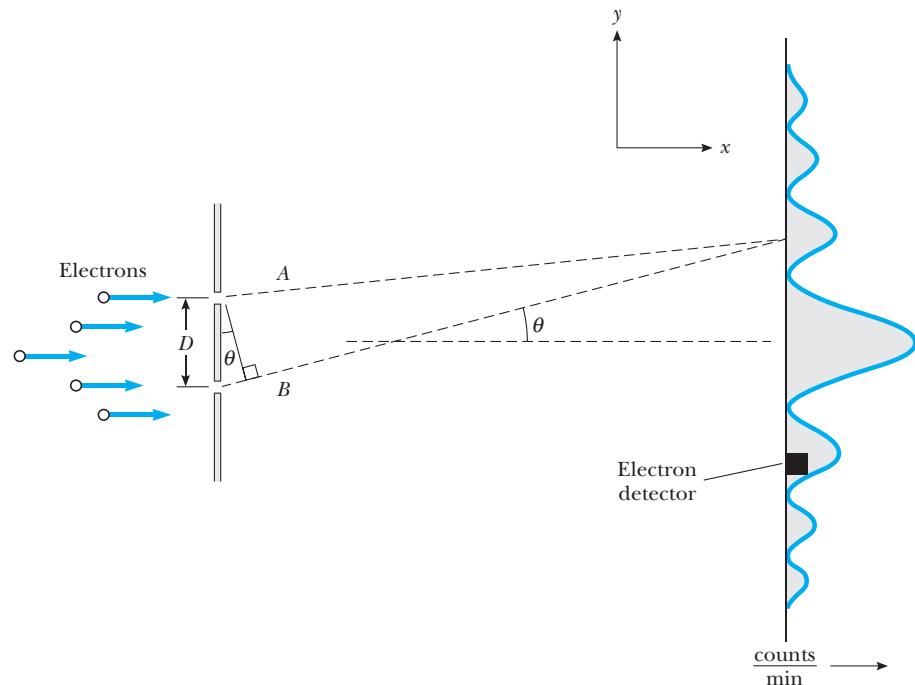

Figure 5.28 Electron diffraction. D is much greater than the individual slit widths and much less than the distance between the slits and the detector.

⁹R. Feynman, *The Character of Physical Law*, Cambridge, MA, MIT Press, 1982.

Images not available due to copyright restrictions

central probability maximum from its neighboring minimum. The minimum occurs when the path length difference between A and B in Figure 5.28 is half a wavelength, or

$$D \sin \theta = \lambda/2$$

As the electron's wavelength is given by $\lambda = h/p_x$, we see that

$$\sin \theta \approx \theta = \frac{h}{2p_x D} \quad (5.35)$$

for small θ . Thus we can see that the dual nature of the electron is clearly shown in this experiment: **although the electrons are detected as particles at a localized spot at some instant of time, the probability of arrival at that spot is determined by finding the intensity of two interfering matter waves.**

But there is more. What happens if one slit is covered during the experiment? In this case one obtains a symmetric curve peaked around the center of the open slit, much like the pattern formed by bullets shot through a hole in armor plate. Plots of the counts per minute or probability of arrival of electrons with the lower or upper slit *closed* are shown in Figure 5.30. These are expressed as the appropriate square of the absolute value of some wavefunction, $|\Psi_1|^2 = \Psi_1^* \Psi_1$ or $|\Psi_2|^2 = \Psi_2^* \Psi_2$, where Ψ_1 and Ψ_2 represent the cases of the electron passing through slit 1 and slit 2, respectively. If an experiment is now performed with slit 1 open and slit 2 blocked for time T and then slit 1 blocked and slit 2 open for time T , the accumulated pattern of counts per minute is completely different from the case with

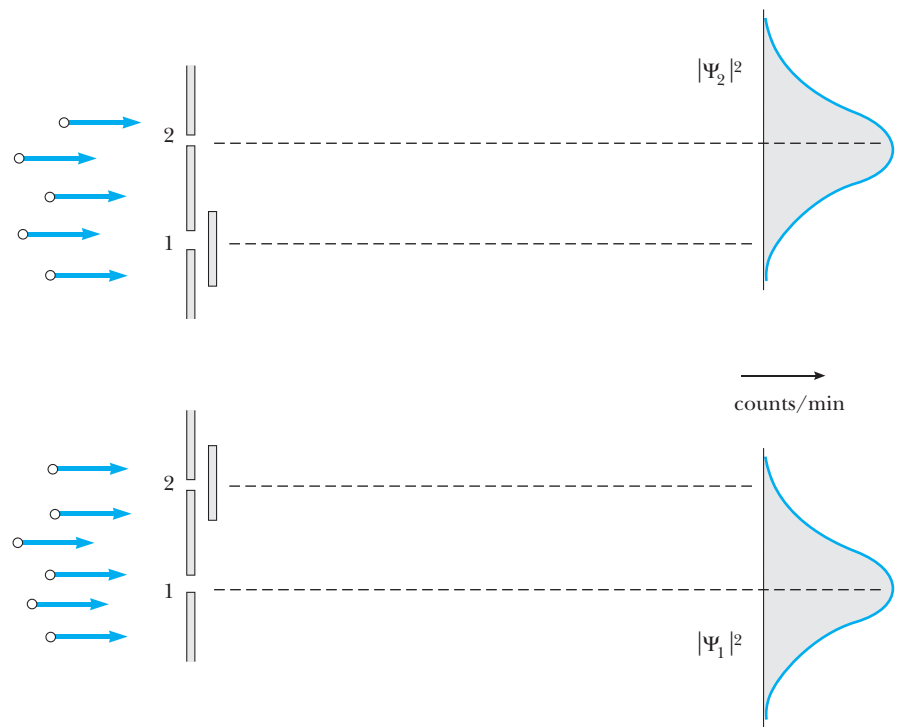

Figure 5.30 The probability of finding electrons at the screen with either the lower or upper slit closed.

both slits open. Note in Figure 5.31 that there is no longer a maximum probability of arrival of an electron at $\theta = 0$. In fact, **the interference pattern has been lost and the accumulated result is simply the sum of the individual results.** The results shown by the black curves in Figure 5.31 are easier to understand and more reasonable than the interference effects seen with both slits open (blue curve). When only one slit is open at a time, we know the electron has the same localizability and indivisibility at the slits as we measure at the detector, because the electron clearly goes through slit 1 or slit 2. Thus, the total must be analyzed as the sum of those electrons that come through slit 1, $|\Psi_1|^2$, and those that come through slit 2, $|\Psi_2|^2$. When both slits are open, it is tempting to assume that the electron goes through either slit 1 or slit 2 and that the counts per minute are again given by $|\Psi_1|^2 + |\Psi_2|^2$. We know, however, that the experimental results contradict this. Thus, our assumption that the electron is localized and goes through only one slit when both slits are open must be wrong (a painful conclusion!). Somehow the electron must be simultaneously present at both slits in order to exhibit interference.

To find the probability of detecting the electron at a particular point on the screen with both slits open, we may say that the electron is in a *superposition state* given by

$$\Psi = \Psi_1 + \Psi_2$$

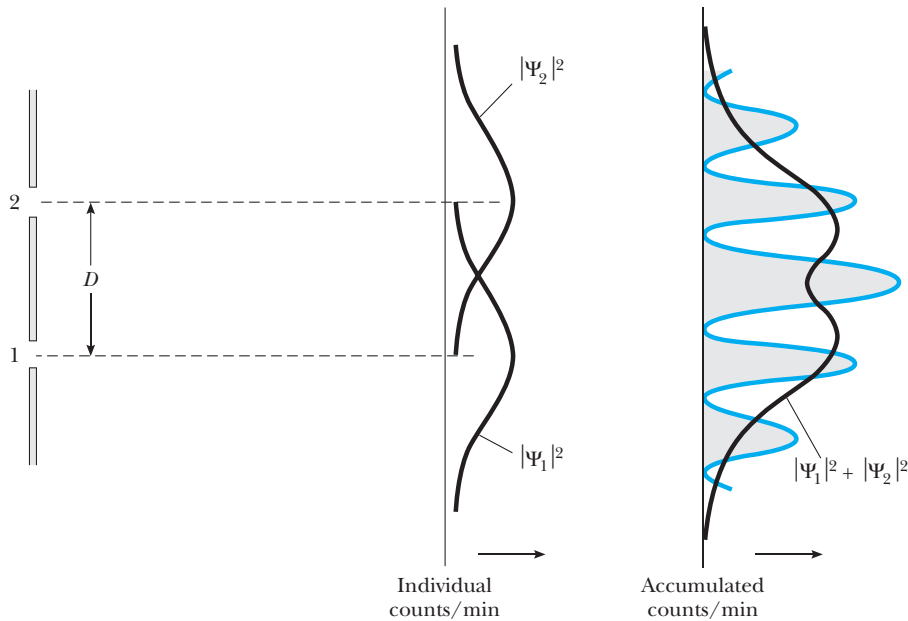

Figure 5.31 Accumulated results from the two-slit electron diffraction experiment with each slit closed half the time. For comparison, the results with both slits open are shown in color.

Thus, the probability of detecting the electron at the screen is equal to the quantity $|\Psi_1 + \Psi_2|^2$ and not $|\Psi_1|^2 + |\Psi_2|^2$. Because matter waves that start out in phase at the slits in general travel different distances to the screen (see Fig. 5.28), Ψ_1 and Ψ_2 will possess a relative phase difference ϕ at the screen. Using a phasor diagram (Fig. 5.32) to find $|\Psi_1 + \Psi_2|^2$ immediately yields

$$|\Psi|^2 = |\Psi_1 + \Psi_2|^2 = |\Psi_1|^2 + |\Psi_2|^2 + 2|\Psi_1||\Psi_2| \cos\phi$$

Note that the term $2|\Psi_1||\Psi_2| \cos\phi$ is an interference term that predicts the interference pattern actually observed in this case. For ease of comparison, a summary of the results found in both cases is given in Table 5.1.

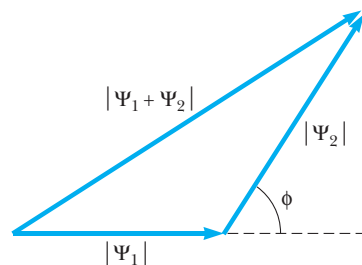

Figure 5.32 Phasor diagram to represent the addition of two complex wavefunctions, Ψ_1 and Ψ_2 , differing in phase by ϕ .

Table 5.1

| Case | Wavefunction | Counts/Minute at Screen |
|---|----------------------|---|
| Electron is measured to pass through slit 1 or slit 2 | Ψ_1 or Ψ_2 | $ \Psi_1 ^2 + \Psi_2 ^2$ |
| No measurements made on electron at slits | $\Psi_1 + \Psi_2$ | $ \Psi_1 ^2 + \Psi_2 ^2 + 2 \Psi_1 \Psi_2 \cos \phi$ |

A Thought Experiment: Measuring Through Which Slit the Electron Passes

Another way to view the electron double-slit experiment is to say that the electron passes through the upper or lower slit only when one *measures* the electron to do so. Once one measures unambiguously which slit the electron passes through (yes, you guessed it . . . here comes the uncertainty principle again . . .), the act of measurement disturbs the electron’s path enough to destroy the delicate interference pattern.

Let us look again at our two-slit experiment to see in detail how the interference pattern is destroyed.¹⁰ To determine which slit the electron goes through, imagine that a group of particles is placed right behind the slits, as shown in Figure 5.33. If we use the recoil of a small particle to determine

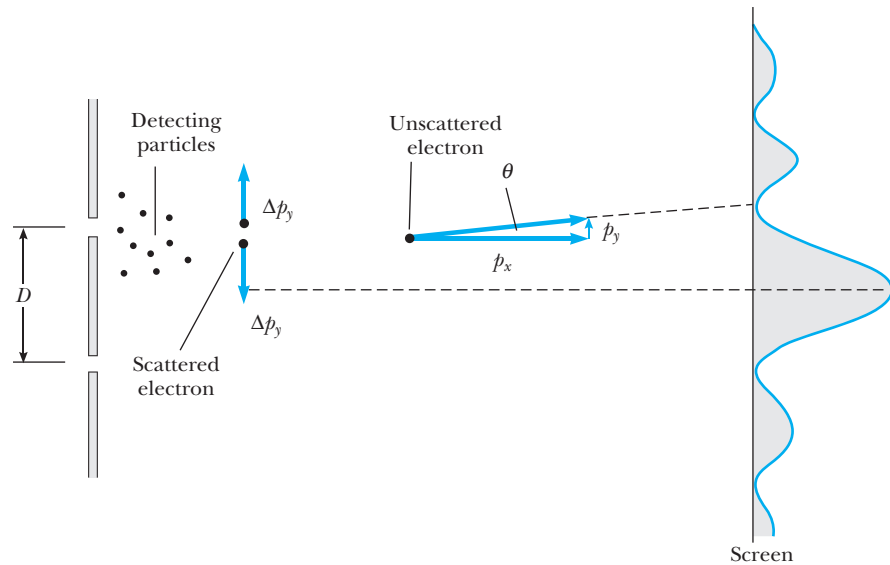

Figure 5.33 A thought experiment to determine through which slit the electron passes.

¹⁰Although we shall use the uncertainty principle in its standard form, it is worth noting that an alternative statement of the uncertainty principle involves this pivotal double-slit experiment: *It is impossible to design any device to determine through which slit the electron passes that will not at the same time disturb the electron and destroy the interference pattern.*

which slit the electron goes through, we must have the uncertainty in the detecting particle's position, $\Delta y \ll D$. Also, during the collision the detecting particle suffers a change in momentum, Δp_y , equal and opposite to the change in momentum experienced by the electron, as shown in Figure 5.33. An undeviated electron landing at the first minimum *and producing an interference pattern* has

$$\tan \theta \approx \theta = \frac{p_y}{p_x} = \frac{h}{2p_x D}$$

from Equation 5.35. Thus, we require that an electron scattered by a detecting particle have

$$\frac{\Delta p_y}{p_x} \ll \theta = \frac{h}{2p_x D}$$

or

$$\Delta p_y \ll \frac{h}{2D}$$

if the interference pattern is not to be distorted. Because the change in momentum of the scattered electron is equal to the change in momentum of the detecting particle, $\Delta p_y \ll h/2D$ also applies to the detecting particle. Thus, we have for the detecting particle

$$\Delta p_y \Delta y \ll \frac{h}{2D} \cdot D$$

or

$$\Delta p_y \Delta y \ll \frac{h}{2}$$

This is a clear violation of the uncertainty principle. Hence we see that **the small uncertainties needed, both to observe interference and to know which slit the electron goes through, are impossible, because they violate the uncertainty principle.** If Δy is small enough to determine which slit the electron goes through, Δp_y is so large that electrons heading for the first minimum are scattered into adjacent maxima and the interference pattern is destroyed.

Exercise 6 In a real experiment it is likely that some electrons would miss the detecting particles. Thus, we would really have two categories of electrons arriving at the detector: those measured to pass through a definite slit and those not observed, or just missed, at the slits. In this case what kind of pattern of counts per minute would be accumulated by the detector?

Answer A mixture of an interference pattern $|\Psi_1 + \Psi_2|^2$ (those not measured) and $|\Psi_1|^2 + |\Psi_2|^2$ (those measured) would result.

5.8 A FINAL NOTE

Scientists once viewed the world as being made up of distinct and unchanging parts that interact according to strictly deterministic laws of cause and effect. In the classical limit this is fundamentally correct because classical processes involve so many quanta that deviations from the average are imperceptible. At the atomic level, however, we have seen that a given piece of matter (an electron, say) is not a distinct and unchanging part of the universe obeying completely deterministic laws. Such a particle exhibits wave properties when it interacts with a metal crystal and particle properties a short while later when it registers on a Geiger counter. Thus, rather than viewing the electron as a distinct and separate part of the universe with an intrinsic particle nature, we are led to the view that the electron and indeed all particles are amorphous entities possessing the potential to cycle endlessly between wave and particle behavior. We also find that it is much more difficult to separate the object measured from the measuring instrument at the atomic level, because the type of measuring instrument determines whether wave properties or particle properties are observed.

SUMMARY

Every lump of matter of mass m and momentum p has wavelike properties with wavelength given by the de Broglie relation

$$\lambda = \frac{h}{p} \quad (5.1)$$

By applying this wave theory of matter to electrons in atoms, de Broglie was able to explain the appearance of integers in certain Bohr orbits as a natural consequence of electron wave interference. In 1927, Davisson and Germer demonstrated directly the wave nature of electrons by showing that low-energy electrons were diffracted by single crystals of nickel. In addition, they confirmed Equation 5.1.

Although the wavelength of matter waves can be experimentally determined, it is important to understand that they are not just like other waves because their frequency and phase velocity cannot be directly measured. In particular, the phase velocity of an individual matter wave is greater than the velocity of light and varies with wavelength or wavenumber as

$$v_p = f\lambda = \left(\frac{E}{h}\right)\left(\frac{h}{p}\right) = c \left[1 + \left(\frac{mc}{\hbar k}\right)^2\right]^{1/2} \quad (5.24)$$

To represent a particle properly, a superposition of matter waves with different wavelengths, amplitudes, and phases must be chosen to interfere constructively over a limited region of space. The resulting wave packet or group can then be shown to travel with the same speed as the classical particle. In addition, a wave packet localized in a region Δx contains a range of wavenumbers Δk , where $\Delta x \Delta k \geq \frac{1}{2}$. Because $p_x = \hbar k$, this implies that there is an uncertainty principle for position and momentum:

$$\Delta p_x \Delta x \geq \frac{\hbar}{2} \quad (5.31)$$

In a similar fashion one can show that an energy–time uncertainty relation exists, given by

$$\Delta E \Delta t \geq \frac{\hbar}{2} \quad (5.34)$$

In quantum mechanics matter waves are represented by a wavefunction $\Psi(x, y, z, t)$. The probability of finding a particle represented by Ψ in a small volume centered at (x, y, z) at time t is proportional to $|\Psi|^2$. The wave–particle duality of electrons may be seen by considering the passage of electrons through two narrow slits and their arrival at a viewing screen. We find that although the electrons are detected as particles at a localized spot on the screen, the probability of arrival at that spot is determined by finding the intensity of two interfering matter waves.

Although we have seen the importance of matter waves or wavefunctions in this chapter, we have provided no method of finding Ψ for a given physical system. In the next chapter we introduce the Schrödinger wave equation. The solutions to this important differential equation will provide us with the wavefunctions for a given system.

SUGGESTIONS FOR FURTHER READING

1. D. Bohm, *Quantum Theory*, Englewood Cliffs, NJ, Prentice-Hall, 1951. Chapters 3 and 6 in this book give an excellent account of wave packets and the wave–particle duality of matter at a more advanced level.
2. R. Feynman, *The Character of Physical Law*, Cambridge, MA, The MIT Press, 1982, Chapter 6. This monograph is an incredibly lively and readable treatment of the double-slit experiment presented in Feynman’s inimitable fashion.
3. B. Hoffman, *The Strange Story of the Quantum*, New York, Dover Publications, 1959. This short book presents a beautifully written nonmathematical discussion of the history of quantum mechanics.

QUESTIONS

1. Is light a wave or a particle? Support your answer by citing specific experimental evidence.
2. Is an electron a particle or a wave? Support your answer by citing some experimental results.
3. An electron and a proton are accelerated from rest through the same potential difference. Which particle has the longer wavelength?
4. If matter has a wave nature, why is this wavelike character not observable in our daily experiences?
5. In what ways does Bohr’s model of the hydrogen atom violate the uncertainty principle?
6. Why is it impossible to measure the position and speed of a particle simultaneously with infinite precision?
7. Suppose that a beam of electrons is incident on three or more slits. How would this influence the interference pattern? Would the state of an electron depend on the number of slits? Explain.
8. In describing the passage of electrons through a slit and arriving at a screen, Feynman said that “electrons arrive in lumps, like particles, but the probability of arrival of these lumps is determined as the intensity of the waves would be. It is in this sense that the electron behaves sometimes like a particle and sometimes like a wave.” Elaborate on this point in your own words. (For a further discussion of this point, see R. Feynman, *The Character of Physical Law*, Cambridge, MA, MIT Press, 1982, Chapter 6.)
9. Do you think that most major experimental discoveries are made by careful planning or by accident? Cite examples.
10. In the case of accidental discoveries, what traits must the experimenter possess to capitalize on the discovery?
11. Are particles even things? An extreme view of the plasticity of electrons and other particles is expressed in this fa-

mous quote of Heisenberg: “The invisible elementary particle of modern physics does not have the property of occupying space any more than it has properties like color or solidity. Fundamentally, it is not a material structure in space and time but only a symbol that allows the laws of nature to be expressed in especially simple form.”

PROBLEMS

5.1 The Pilot Waves of de Broglie

1. Calculate the de Broglie wavelength for a proton moving with a speed of 10^6 m/s.
2. Calculate the de Broglie wavelength for an electron with kinetic energy (a) 50 eV and (b) 50 keV.
3. Calculate the de Broglie wavelength of a 74-kg person who is running at a speed of 5.0 m/s.
4. The “seeing” ability, or resolution, of radiation is determined by its wavelength. If the size of an atom is of the order of 0.1 nm, how fast must an electron travel to have a wavelength small enough to “see” an atom?
5. To “observe” small objects, one measures the diffraction of particles whose de Broglie wavelength is approximately equal to the object’s size. Find the kinetic energy (in electron volts) required for electrons to resolve (a) a large organic molecule of size 10 nm, (b) atomic features of size 0.10 nm, and (c) a nucleus of size 10 fm. Repeat these calculations using alpha particles in place of electrons.
6. An electron and a photon each have kinetic energy equal to 50 keV. What are their de Broglie wavelengths?
7. Calculate the de Broglie wavelength of a proton that is accelerated through a potential difference of 10 MV.
8. Show that the de Broglie wavelength of an electron accelerated from rest through a small potential difference V is given by $\lambda = 1.226/\sqrt{V}$, where λ is in nanometers and V is in volts.
9. Find the de Broglie wavelength of a ball of mass 0.20 kg just before it strikes the Earth after being dropped from a building 50 m tall.
10. An electron has a de Broglie wavelength equal to the diameter of the hydrogen atom. What is the kinetic energy of the electron? How does this energy compare with the ground-state energy of the hydrogen atom?
11. For an electron to be confined to a nucleus, its de Broglie wavelength would have to be less than 10^{-14} m. (a) What would be the kinetic energy of an electron confined to this region? (b) On the basis of this result, would you expect to find an electron in a nucleus? Explain.
12. Through what potential difference would an electron have to be accelerated to give it a de Broglie wavelength of 1.00×10^{-10} m?

Are you satisfied with viewing science as a set of predictive rules or do you prefer to see science as a description of an objective world of things—in the case of particle physics, tiny, scaled-down things? What problems are associated with each point of view?

5.2 The Davisson–Germer Experiment

13. Figure P5.13 shows the top three planes of a crystal with planar spacing d . If $2d \sin \theta = 1.01\lambda$ for the two waves shown, and high-energy electrons of wavelength λ penetrate many planes deep into the crystal, which atomic plane produces a wave that cancels the surface reflection? This is an example of how extremely narrow maxima in high-energy electron diffraction are formed—that is, there are no diffracted beams unless $2d \sin \theta$ is equal to an integral number of wavelengths.

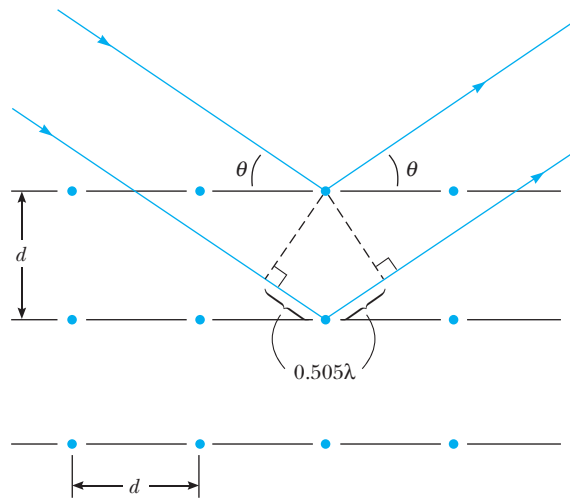

Figure P5.13

14. (a) Show that the formula for low-energy electron diffraction (LEED), when electrons are incident perpendicular to a crystal surface, may be written as

$$\sin \phi = \frac{nhc}{d(2m_e c^2 K)^{1/2}}$$

where n is the order of the maximum, d is the atomic spacing, m_e is the electron mass, K is the electron’s kinetic energy, and ϕ is the angle between the incident and diffracted beams. (b) Calculate the atomic spacing

in a crystal that has consecutive diffraction maxima at $\phi = 24.1^\circ$ and $\phi = 54.9^\circ$ for 100-eV electrons.

5.3 Wave Groups and Dispersion

15. Show that the group velocity for a nonrelativistic free electron is also given by $v_g = p/m_e = v_0$, where v_0 is the electron's velocity.
16. When a pebble is tossed into a pond, a circular wave pulse propagates outward from the disturbance. If you are alert (and it's not a sleepy afternoon in late August), you will see a fine structure in the pulse consisting of surface ripples moving inward through the circular disturbance. Explain this effect in terms of group and phase velocity if the phase velocity of ripples is given by $v_p = \sqrt{2\pi S/\lambda\rho}$, where S is the surface tension and ρ is the density of the liquid.
17. The dispersion relation for free relativistic electron waves is

$$\omega(k) = \sqrt{c^2 k^2 + (m_e c^2/\hbar)^2}$$

Obtain expressions for the phase velocity v_p and group velocity v_g of these waves and show that their product is a constant, independent of k . From your result, what can you conclude about v_g if $v_p > c$?

5.5 The Heisenberg Uncertainty Principle

18. A ball of mass 50 g moves with a speed of 30 m/s. If its speed is measured to an accuracy of 0.1%, what is the minimum uncertainty in its position?
19. A proton has a kinetic energy of 1.0 MeV. If its momentum is measured with an uncertainty of 5.0%, what is the minimum uncertainty in its position?
20. We wish to measure simultaneously the wavelength and position of a photon. Assume that the wavelength measurement gives $\lambda = 6000 \text{ \AA}$ with an accuracy of one part in a million, that is, $\Delta\lambda/\lambda = 10^{-6}$. What is the minimum uncertainty in the position of the photon?
21. A woman on a ladder drops small pellets toward a spot on the floor. (a) Show that, according to the uncertainty principle, the miss distance must be at least

$$\Delta x = \left(\frac{\hbar}{2m}\right)^{1/2} \left(\frac{H}{2g}\right)^{1/4}$$

where H is the initial height of each pellet above the floor and m is the mass of each pellet. (b) If $H = 2.0 \text{ m}$ and $m = 0.50 \text{ g}$, what is Δx ?

22. A beam of electrons is incident on a slit of variable width. If it is possible to resolve a 1% difference in momentum, what slit width would be necessary to resolve the interference pattern of the electrons if their kinetic energy is (a) 0.010 MeV, (b) 1.0 MeV, and (c) 100 MeV?
23. Suppose Fuzzy, a quantum-mechanical duck, lives in a world in which $\hbar = 2\pi \text{ J}\cdot\text{s}$. Fuzzy has a mass of 2.0 kg and is initially known to be within a region 1.0 m wide.

- (a) What is the minimum uncertainty in his speed?
- (b) Assuming this uncertainty in speed to prevail for 5.0 s, determine the uncertainty in position after this time.

24. An electron of momentum p is at a distance r from a stationary proton. The system has a kinetic energy $K = p^2/2m_e$ and potential energy $U = -ke^2/r$. Its total energy is $E = K + U$. If the electron is bound to the proton to form a hydrogen atom, its average position is at the proton but the uncertainty in its position is approximately equal to the radius, r , of its orbit. The electron's average momentum will be zero, but the uncertainty in its momentum will be given by the uncertainty principle. Treat the atom as a one-dimensional system in the following: (a) Estimate the uncertainty in the electron's momentum in terms of r . (b) Estimate the electron's kinetic, potential, and total energies in terms of r . (c) The actual value of r is the one that minimizes the total energy, resulting in a stable atom. Find that value of r and the resulting total energy. Compare your answer with the predictions of the Bohr theory.
25. An excited nucleus with a lifetime of 0.100 ns emits a γ ray of energy 2.00 MeV. Can the energy width (uncertainty in energy, ΔE) of this 2.00-MeV γ emission line be directly measured if the best gamma detectors can measure energies to $\pm 5 \text{ eV}$?
26. Typical measurements of the mass of a subatomic delta particle ($m \approx 1230 \text{ MeV}/c^2$) are shown in Figure P5.26. Although the lifetime of the delta is much too short to measure directly, it can be calculated from the energy–time uncertainty principle. Estimate the lifetime from the full width at half-maximum of the mass measurement distribution shown.

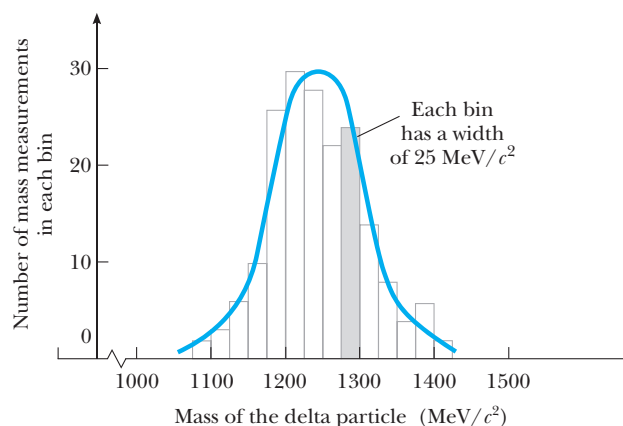

Figure P5.26 Histogram of mass measurements of the delta particle.

5.7 The Wave-Particle Duality

27. A monoenergetic beam of electrons is incident on a single slit of width 0.50 nm. A diffraction pattern is

formed on a screen 20 cm from the slit. If the distance between successive minima of the diffraction pattern is 2.1 cm, what is the energy of the incident electrons?

28. A neutron beam with a selected speed of 0.40 m/s is directed through a double slit with a 1.0-mm separation. An array of detectors is placed 10 m from the slit. (a) What is the de Broglie wavelength of the neutrons? (b) How far off axis is the first zero-intensity point on the detector array? (c) Can we say which slit any particular neutron passed through? Explain.
29. A two-slit electron diffraction experiment is done with slits of *unequal* widths. When only slit 1 is open, the number of electrons reaching the screen per second is 25 times the number of electrons reaching the screen per second when only slit 2 is open. When both slits are open, an interference pattern results in which the destructive interference is not complete. Find the ratio of the probability of an electron arriving at an interference maximum to the probability of an electron arriving at an adjacent interference minimum. (*Hint:* Use the superposition principle).

Additional Problems

30. Robert Hofstadter won the 1961 Nobel prize in physics for his pioneering work in scattering 20-GeV electrons from nuclei. (a) What is the γ factor for a 20-GeV electron, where $\gamma = (1 - v^2/c^2)^{-1/2}$? What is the momentum of the electron in kg·m/s? (b) What is the wavelength of a 20-GeV electron and how does it compare with the size of a nucleus?
31. An air rifle is used to shoot 1.0-g particles at 100 m/s through a hole of diameter 2.0 mm. How far from the rifle must an observer be to see the beam spread by 1.0 cm because of the uncertainty principle? Compare this answer with the diameter of the Universe (2×10^{26} m).
32. An atom in an excited state 1.8 eV above the ground state remains in that excited state $2.0 \mu\text{s}$ before moving to the ground state. Find (a) the frequency of the emitted photon, (b) its wavelength, and (c) its approximate uncertainty in energy.
33. A π^0 meson is an unstable particle produced in high-energy particle collisions. It has a mass–energy equivalent of about 135 MeV, and it exists for an average lifetime of only 8.7×10^{-17} s before decaying into two γ rays. Using the uncertainty principle, estimate the fractional uncertainty $\Delta m/m$ in its mass determination.
34. (a) Find and sketch the spectral content of the rectangular pulse of width 2τ shown in Figure P5.34. (b) Show that a reciprocity relation $\Delta\omega \Delta t \approx \pi$ holds

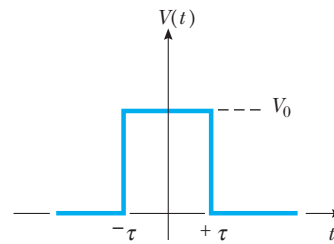

Figure P5.34

in this case. Take $\Delta t = \tau$ and define $\Delta\omega$ similarly. (c) What range of frequencies is required to compose a pulse of width $2\tau = 1 \mu\text{s}$? A pulse of width $2\tau = 1 \text{ ns}$?

35. A matter wave packet. (a) Find and sketch the real part of the matter wave pulse shape $f(x)$ for a Gaussian amplitude distribution $a(k)$, where

$$a(k) = Ae^{-\alpha^2(k-k_0)^2}$$

Note that $a(k)$ is peaked at k_0 and has a width that decreases with increasing α . (*Hint:* In order to put

$f(x) = (2\pi)^{-1/2} \int_{-\infty}^{+\infty} a(k)e^{ikx} dk$ into the standard

form $\int_{-\infty}^{+\infty} e^{-az^2} dz$, complete the square in k .) (b) By

comparing the result for the real part of $f(x)$ to the standard form of a Gaussian function with width Δx , $f(x) \propto Ae^{-(x/2\Delta x)^2}$, show that the width of the matter wave pulse is $\Delta x = \alpha$. (c) Find the width Δk of $a(k)$ by writing $a(k)$ in standard Gaussian form and show that $\Delta x \Delta k = \frac{1}{2}$, independent of α .

36. Consider a freely moving quantum particle with mass m and speed v . Its energy is $E = K + U = \frac{1}{2}mv^2 + 0$. Determine the phase speed of the quantum wave representing the particle and show that it is different from the speed at which the particle transports mass and energy.
37. In a vacuum tube, electrons are boiled out of a hot cathode at a slow, steady rate and accelerated from rest through a potential difference of 45.0 V. Then they travel altogether 28.0 cm as they go through an array of slits and fall on a screen to produce an interference pattern. Only one electron at a time will be in flight in the tube, provided the beam current is below what value? In this situation the interference pattern still appears, showing that each individual electron can interfere with itself.